

HIWIN®

Motion Control & Systems

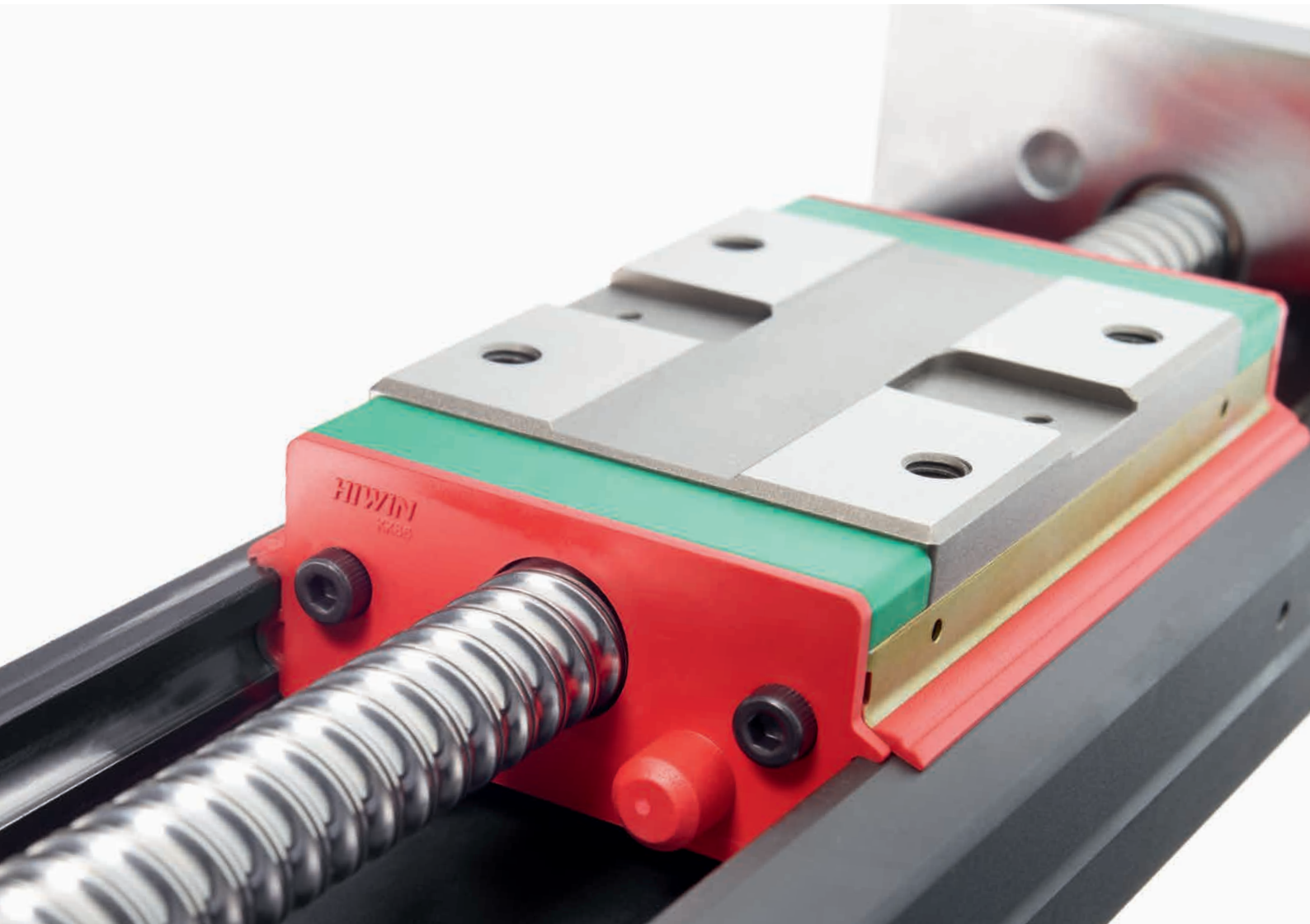

Positioning Systems

Linear Axes with Ballscrew
Accessories

HIWIN[®]

Motion Control & Systems

Welcome to HIWIN

Linear axes are used in many areas of industry to transport or to position. HIWIN supplies linear axes with ballscrews for a range of applications. For situations where greater precision is needed, the HIWIN product range also includes direct-driven linear motor systems. You will find these in our linear motor systems catalogue.

KK Linear Axes

Contents

Contents

1. General information	6
1.1 Characteristics of KK linear axes	6
1.2 Structure of KK linear axes	6
1.3 Order code for KK linear axes	7
1.4 Service life calculation	8
1.5 Ambient conditions	11
1.6 Glossary	11
1.7 Technical data of KK linear axes with and without HIWIN servo motor	12
2. KK Linear Axes	14
2.1 KK40	14
2.2 KK50	17
2.3 KK60	20
2.4 KK86	26
2.5 KK100	32
2.6 KK130	35
3. Accessories for KK linear axes	38
3.1 HIWIN servo motor	38
3.2 HIWIN D2 servo drive	39
3.3 Sensor rail with limit switch	39
3.4 Cross table adapter	40
3.5 Covers	41
3.6 Grease nipples	41

KK Linear Axes

General information

1. General information

1.1 Characteristics of KK linear axes

HIWIN KK linear axes are compact positioning axes which are supplied fully fitted with HIWIN servo motor and HIWIN servo drive. Alternatively, the KK linear axis can also be supplied with "motor-ready" mountings for connecting to customer-specific motors. High levels of accuracy and rigidity are achieved through a linear guideway in the steel profile with integrated ballscrew.

The axis is available in different sizes and lengths and can be adapted to the application requirements through additional options such as aluminium covers, bellow covers, limit switches and additional blocks.



Advantages of KK linear axes

- Ready-to-install complete axis with HIWIN servo motor and HIWIN drive
- Universal use
- Compact design
- Adaptable and robust
- High precision and rigidity

1.2 Structure of KK linear axes

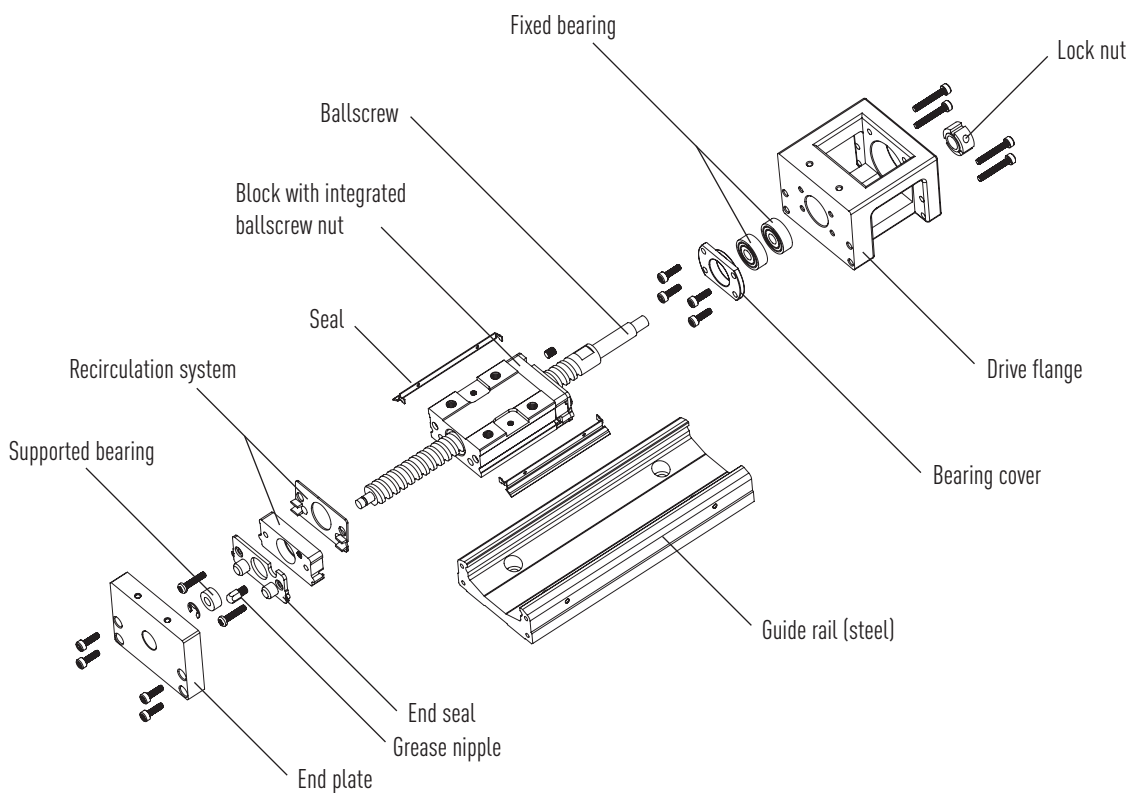

1.3 Order code for KK linear axes

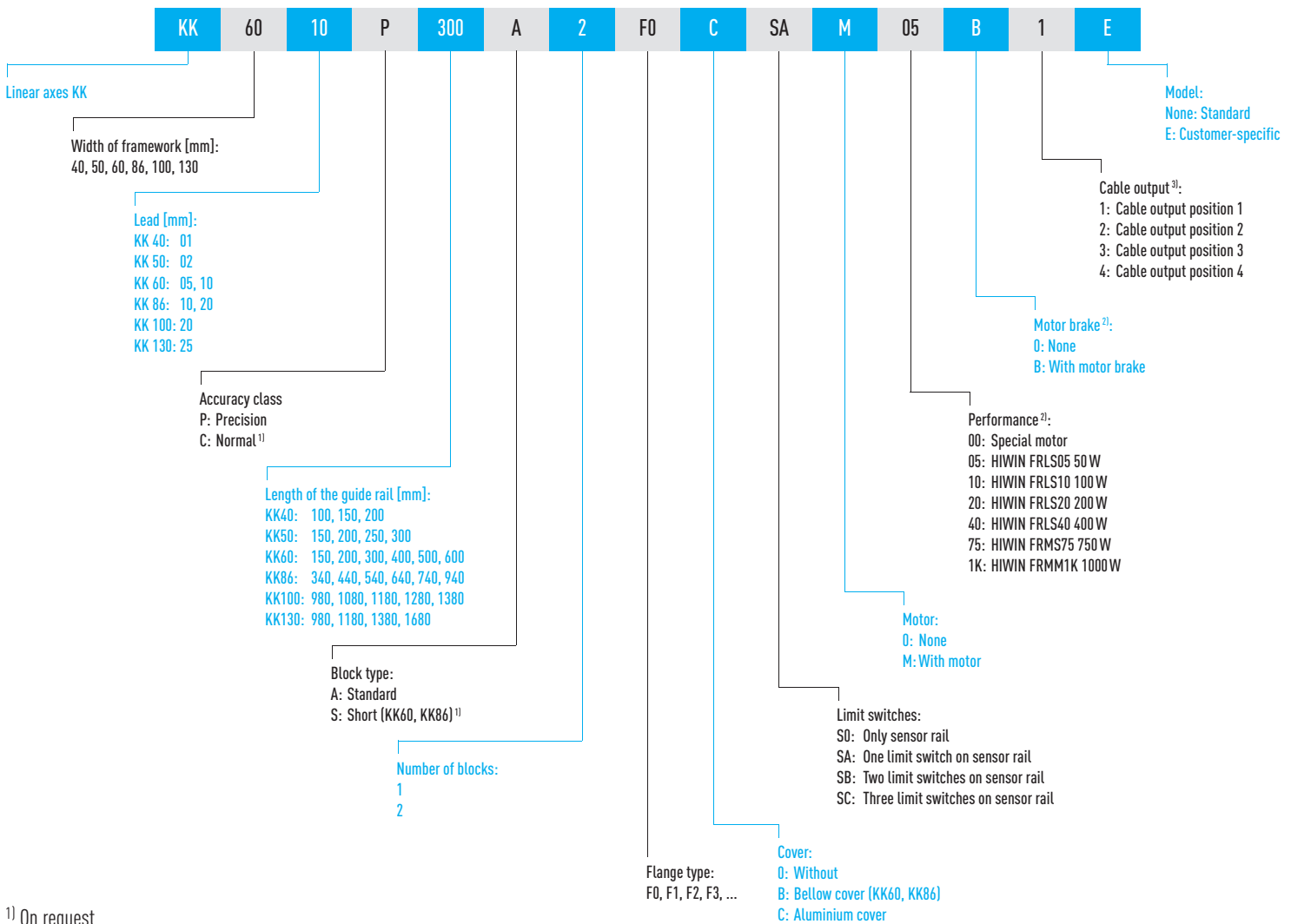

¹⁾ On request

²⁾ Does not apply to models without motor

³⁾ See Fig. 1.1

The item numbers for the associated HIWIN servo motors and HIWIN drives and extension cables can be found in tables Table 3.2 and Table 3.3.

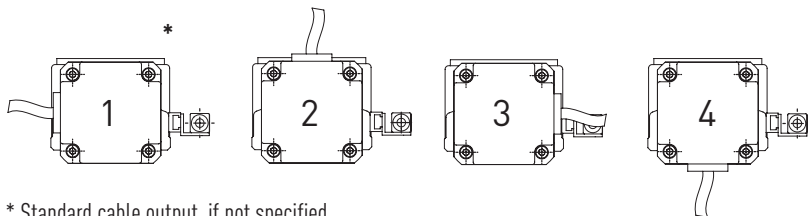

Fig. 1.1 Illustration of cable output

* Standard cable output, if not specified

Table 1.1 Assignment of flange type to motor type

Motor output	Motor type	Flange type					
		KK40	KK50	KK60	KK86	KK100	KK130
50 W	FRLS05	F2	F2	F2			
100 W	FRLS10	F2	F2	F2			
200 W	FRLS20				F0	F0	F1
400 W	FRLS40				F0	F0	F1
750 W	FRMS75					F1	F0
1000 W	FRMM1K						F5

KK Linear Axes

General information

1.4 Service life calculation

The constant, repeated load on blocks and spindles results in signs of fatigue and eventually pitting on the track surface. The service life of a linear axis is defined as the total distance travelled until pitting appears on the surface of the track or spindle.

1.4.1 Nominal service life (L)

The service life may vary significantly even between linear axes that were manufactured in the same way and are used under the same motion conditions. So the nominal service life serves as a guideline to estimate the service life of a linear axis. The nominal service life corresponds to the total distance travelled that will be achieved by 90 % of a group of identical linear axes used under the same conditions without failure.

Calculation of nominal service life (L)

The actual calculation influences the nominal service life of a linear axis. When the selected dynamic load rating and the dynamic equivalent load are known, the nominal service life can be calculated using the formulas [F 1.1](#) and [F 1.2](#).

- Nominal service life of ballscrew

$$F 1.1 \quad L = \left(\frac{C_{dyn}}{f_p \times F_{bm}} \right)^3 \times 10^6$$

L Nominal service life in revolutions
 C_{dyn} Dynamic load rating [N]
 F_{bm} Dynamic equivalent load (axial) [N]
 f_p Ballscrew load factor

- Nominal service life of linear guideway

$$F 1.2 \quad L = \left(\frac{C_{dyn}}{f_w \times F_{bm}} \right)^3 \times 50 \text{ km}$$

L Nominal service life in kilometres
 C_{dyn} Dynamic load rating [N]
 F_{bm} Dynamic equivalent load [N]
 f_w Linear guideway load factor

Load factor (f_p , f_w)

The loads that act on a linear axis include the weight of the block, the inertia at the start and end of a movement and the load torque created by the projecting load. These load factors are especially difficult to gauge when vibrations or impact loads are added. The load should therefore be multiplied by the empirical load factor. In short-stroke applications (stroke < 2 × block length) the calculated load factor should be doubled.

Table 1.2 Ballscrew load factor

Type of load	f_p
Operation without impact	1.1 – 1.2
Operation under normal conditions	1.3 – 1.8
Operation with high impact and vibrations	2.0 – 3.0
Short-stroke applications (< 3 × nut length)	3.0 – 5.0

Table 1.3 Linear guideway load factor

Type of load	Travel speed	f_w
No impact or vibrations	up to 15 m/min	1.0 – 1.2
Normal load	15 m/min to 60 m/min	1.2 – 1.5
Minor impacts	60 m/min to 120 m/min	1.5 – 2.0
With impact and vibrations	over 120 m/min	2.0 – 3.5

1.4.1.1 Calculation of service life of linear guideway

Because the load of a block varies considerably, an equivalent load must be used to calculate the service life. The equivalent load is defined as the load that causes the same wear on the bearings as the variable load. Constant operating conditions are not taken into account.

- Combined dynamic equivalent load

F 1.3

$$F_{bm} = F + M \times \frac{C_0}{M_0}$$

F_{bm}	Dynamic equivalent load [N]
C_0	Static load rating [N]
M_0	Static moment [Nm]
M	Directly effective moment (around X, Y or Z axis) [Nm]
F	Effective force (in Y or Z direction) [N]

This formula is a simplified way of calculating the dynamic equivalent load. If you require more information, please contact HIWIN.

Example calculation of service life of linear guideway

- Service life calculation for a KK60 linear axis (when $f_w = 1$)

Specification:	$M_Y = 20 \text{ Nm}$	Moment
	$M_{Y0} = 152 \text{ Nm}$	Static moment ¹⁾
	$C_{dyn} = 13230 \text{ N}$	Dynamic load rating ¹⁾
	$C_0 = 21462 \text{ N}$	Static load rating ¹⁾

¹⁾ For calculated values for load ratings and static moment, see [Table 1.5](#)

$$F_{bm} = F + M \times \frac{C_0}{M_{Y0}} \quad \rightarrow \quad F_{bm} = 0 + 20 \text{ Nm} \times \frac{21462 \text{ N}}{152 \text{ Nm}} \quad \rightarrow \quad F_{bm} = 2823,95 \text{ N}$$

$$L = \left(\frac{C_{dyn}}{f_w \times F_{bm}} \right)^3 \times 50 \text{ km} \quad \rightarrow \quad L = \left(\frac{13230 \text{ N}}{1 \times 2823,95 \text{ N}} \right)^3 \times 50 \text{ km} \quad \rightarrow \quad \underline{\underline{L = 5141 \text{ km}}}$$

With a moment of $M_Y = 20 \text{ Nm}$, the nominal service life of the block in a KK60 linear axis is 5141 km.

For more information, please contact HIWIN.

KK Linear Axes

General information

1.4.1.2 Calculation of service life of ballscrew

The bases of calculation are based on DIN 69051 and/or ISO 3408. For detailed information about configuring a ballscrew, please refer to our "Ballscrews and Accessories" catalogue.

a) Average speed n_m

$$F 1.4 \quad n_m = n_1 \times \frac{t_1}{100} + n_2 \times \frac{t_2}{100} + n_3 \times \frac{t_3}{100} + \dots$$

n_m Average speed, total [rpm]
 n_n Average speed in phase n [rpm]
 t_n Amount of time in phase n [%]

b) Average operating load F_{xm}

○ With alternating load and constant speed:

$$F 1.5 \quad F_{xm} = \sqrt[3]{F_{x1}^3 \times \frac{t_1}{100} \times f_{p1}^3 + F_{x2}^3 \times \frac{t_2}{100} \times f_{p2}^3 + F_{x3}^3 \times \frac{t_3}{100} \times f_{p3}^3 \dots}$$

F_{xm} Average operating load in axial direction [N]
 F_{xn} Operating axial loading in phase n [N]
 f_{pn} Operating condition factor in phase n
 f_p See [Table 1.2](#)

○ With alternating load and alternating speed:

$$F 1.6 \quad F_{xm} = \sqrt[3]{F_{x1}^3 \times \frac{n_1}{n_m} \times \frac{t_1}{100} \times f_{p1}^3 + F_{x2}^3 \times \frac{n_2}{n_m} \times \frac{t_2}{100} \times f_{p2}^3 + F_{x3}^3 \times \frac{n_3}{n_m} \times \frac{t_3}{100} \times f_{p3}^3 \dots}$$

Service life with axial load on both sides

○ Service life in revolutions

$$F 1.7 \quad L_1 = \left(\frac{C_{dyn}}{F_{xm1}} \right)^3 \times 10^6 \quad L_2 = \left(\frac{C_{dyn}}{F_{xm2}} \right)^3 \times 10^6$$

L_1 Service life in revolutions, forward motion
 L_2 Service life in revolutions, backward motion
 C_{dyn} Dynamic load rating [N]
 F_{xm1} Average operating load, forward motion [N]
 F_{xm2} Average operating load, backward motion [N]
 L Service life in revolutions

$$F 1.8 \quad L = \left(L_1^{-10/9} + L_2^{-10/9} \right)^{-9/10}$$

○ Conversion of service life into operating hours

$$F 1.9 \quad L_h = \frac{L}{n_m \times 60}$$

L_h Service life in operating hours
 n_m Average speed [rpm], see formula [F 1.4](#)

○ Conversion of distance travelled [km] into operating hours:

$$F 1.10 \quad L_h = \left(\frac{L_{km} \times 10^6}{P} \right) \times \frac{1}{n_m \times 60}$$

L_h Service life in operating hours
 L_{km} Service life in distance travelled [km]
 P Lead [mm]
 n_m Average speed [rpm], see formula [F 1.4](#)

1.5 Ambient conditions

- Ambient temperature: +5 °C to +40 °C
- Installation site: dry
- Atmosphere: not explosive

1.6 Glossary

Positioning accuracy

According to VDI/DGQ 3441, positioning accuracy describes the maximum deviation between the actual and nominal positions. Positioning accuracy is influenced by the following factors: lead error of spindle, system play, controller parameterisation and the accuracy of the linear unit, transmission, motor and measuring system.

Repeatability

Repeatability describes how accurately the block is stopped and positioned when approaching a given position from the same direction several times. It is stated as the maximum deviation between the actual positions attained.

Guide parallelism

The guide parallelism is measured by aligning a measuring rule parallel to a linear axis mounted on a table. The parallelism of contact faces D and B on the block and profile and of the block top face C to mounting surface A of the profile is then measured. It is assumed that the axis is ideally installed and that the measurement is taken across the centre of the block. Guide parallelism is calculated by subtracting the minimum value from the maximum value.

Breakaway torque

The breakaway torque is the torque needed to overcome the frictional torque.

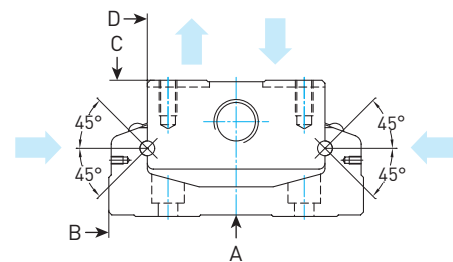

KK Linear Axes

General information

1.7 Technical data of KK linear axes with and without HIWIN servo motor

1.7.1 Accuracy and maximum values of KK linear axes

Table 1.4 Accuracy and maximum values of KK linear axes

Model	Lead [mm]	L1 [mm]	V _{max} [mm/s]		a _{max} [m/s ²]	Accuracy [mm]	Repeatability [mm]	Guideway parallelism [mm]	Starting torque [Nmm]
			without motor	with motor					
KK4001P0100	1	159	190	75	5	0.020	± 0.003	0.010	12
KK4001P0150	1	209	190	75	5	0.020	± 0.003	0.010	12
KK4001P0200	1	259	190	75	5	0.020	± 0.003	0.010	12
KK5002P0150	2	220	270	150	5	0.020	± 0.003	0.010	40
KK5002P0200	2	270	270	150	5	0.020	± 0.003	0.010	40
KK5002P0250	2	320	270	150	5	0.020	± 0.003	0.010	40
KK5002P0300	2	370	270	150	5	0.020	± 0.003	0.010	40
KK6005P0150	5	220	550	375	15	0.020	± 0.003	0.010	150
KK6005P0200	5	270	550	375	15	0.020	± 0.003	0.010	150
KK6005P0300	5	370	550	375	15	0.020	± 0.003	0.010	150
KK6005P0400	5	470	550	375	15	0.020	± 0.003	0.010	150
KK6005P0500	5	570	550	375	15	0.025	± 0.003	0.015	150
KK6005P0600	5	670	340	340	15	0.025	± 0.003	0.015	150
KK6010P0150	10	220	1100	750	15	0.020	± 0.003	0.010	150
KK6010P0200	10	270	1100	750	15	0.020	± 0.003	0.010	150
KK6010P0300	10	370	1100	750	15	0.020	± 0.003	0.010	150
KK6010P0400	10	470	1100	750	15	0.020	± 0.003	0.010	150
KK6010P0500	10	570	1100	750	15	0.025	± 0.003	0.015	150
KK6010P0600	10	670	670	670	15	0.025	± 0.003	0.015	150
KK8610P0340	10	440	740	740	15	0.025	± 0.003	0.015	150
KK8610P0440	10	540	740	740	15	0.025	± 0.003	0.015	150
KK8610P0540	10	640	740	740	15	0.025	± 0.003	0.015	150
KK8610P0640	10	740	740	740	15	0.025	± 0.003	0.015	150
KK8610P0740	10	840	740	740	15	0.030	± 0.003	0.020	170
KK8610P0940	10	1040	610	610	15	0.040	± 0.003	0.030	250
KK8620P0340	20	440	1480	1480	15	0.025	± 0.003	0.015	150
KK8620P0440	20	540	1480	1480	15	0.025	± 0.003	0.015	150
KK8620P0540	20	640	1480	1480	15	0.025	± 0.003	0.015	150
KK8620P0640	20	740	1480	1480	15	0.025	± 0.003	0.015	150
KK8620P0740	20	840	1480	1480	15	0.030	± 0.003	0.020	170
KK8620P0940	20	1040	1220	1220	15	0.040	± 0.003	0.030	250
KK10020P0980	20	1089	1120	1120	15	0.035	± 0.005	0.025	170
KK10020P1080	20	1189	980	980	15	0.035	± 0.005	0.025	170
KK10020P1180	20	1289	750	750	15	0.040	± 0.005	0.030	200
KK10020P1280	20	1389	630	630	15	0.045	± 0.005	0.035	230
KK10020P1380	20	1489	530	530	15	0.050	± 0.005	0.040	250
KK13025P0980	25	1098	1120	1120	15	0.035	± 0.005	0.025	250
KK13025P1180	25	1298	1120	1120	15	0.040	± 0.005	0.030	250
KK13025P1380	25	1498	830	830	15	0.040	± 0.005	0.030	250
KK13025P1680	25	1798	550	550	15	0.050	± 0.007	0.040	270

1.7.2 Load ratings and torques of KK linear axes

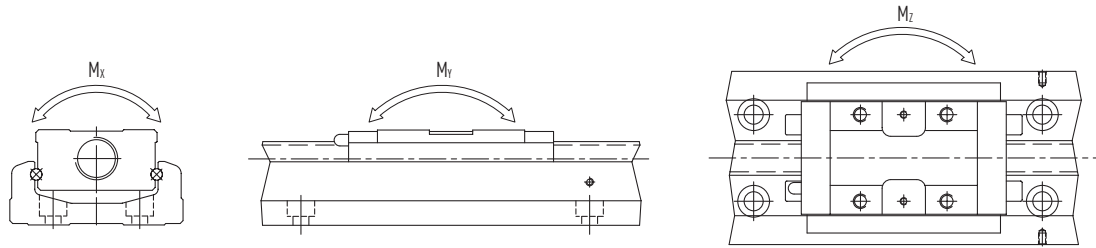

Table 1.5 Load ratings of KK linear axes: linear guideway, standard block

Model	C_{dyn} [N]	C_0 [N]	Block A1			Block A2		
			M_x [Nm]	M_y [Nm]	M_z [Nm]	M_x [Nm]	M_y [Nm]	M_z [Nm]
KK40	3920	6468	81	33	33	162	182	182
KK50	8007	12916	222	116	116	444	545	545
KK60	13230	21462	419	152	152	838	760	760
KK86	31458	50764	1507	622	622	3014	3050	3050
KK100	39200	63406	2205	960	960	4410	4763	4763
KK130	48101	84829	3885	1536	1536	7770	7350	7350

Table 1.6 Load ratings of KK linear axes: linear guideway, short block

Model	C_{dyn} [N]	C_0 [N]	Block S1			Block S2		
			M_x [Nm]	M_y [Nm]	M_z [Nm]	M_x [Nm]	M_y [Nm]	M_z [Nm]
KK60	7173	11574	241	72	72	482	367	367
KK86	21051	29475	847	166	166	1694	1309	1309

Table 1.7 Load ratings of KK linear axes: ballscrew and fixed bearing

Model	Shaft			Fixed bearing	
	\varnothing [mm]	C_{dyn} [N]	C_0 [N]	$C_{0 axial}$ [N]	$F_{max axial}$ [N]
KK4001Pxxxx	8	735	1538	1910	750
KK5002Pxxxx	8	2136	3489	1910	1500
KK6005Pxxxx	12	3744	6243	4480	3120
KK6010Pxxxx	12	2410	3743	4480	1870
KK8610Pxxxx	15	7144	12642	9240	6320
KK8620Pxxxx	15	4645	7655	9240	3825
KK10020Pxxxx	20	7046	12544	10600	6270
KK13025Pxxxx	25	7897	15931	18485	7950

Table 1.8 Area moment of inertia of KK linear axes

Model	Area moment of inertia [mm ⁴]	
	I_x	I_y
KK40	3.533×10^3	5.317×10^4
KK50	9.600×10^3	1.340×10^5
KK60	2.056×10^4	2.802×10^5
KK86	7.445×10^4	1.134×10^6
KK100	1.296×10^5	2.035×10^6
KK130	2.546×10^5	5.073×10^6

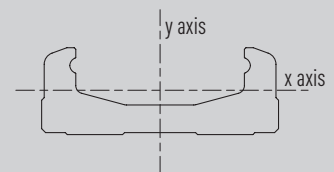

KK Linear Axes

KK40

2. KK Linear Axes

2.1 KK40

2.1.1 KK40 linear axes without cover

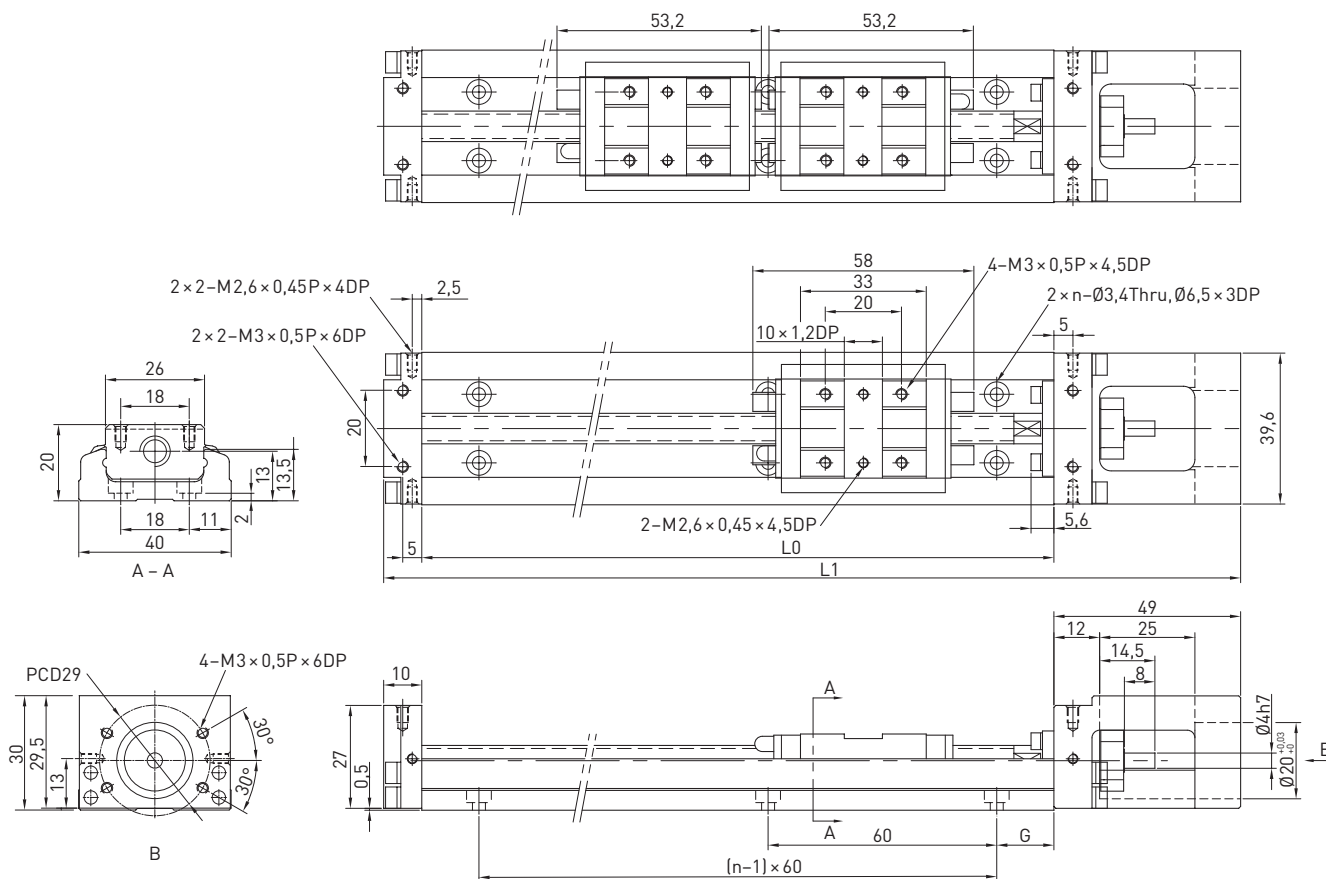

Table 2.1 Dimensions and weights of KK40 linear axes without cover

Model	lead [mm]	L0 [mm]	L1 [mm]	Maximum stroke [mm]		G [mm]	K [mm]	n	m	Weight [kg]	
				Block A1	Block A2					Block A1	Block A2
KK4001P0100	1	100	159	36	—	20	—	2	—	0.48	—
KK4001P0150	1	150	209	86	34	15	—	3	—	0.60	0.67
KK4001P0200	1	200	259	136	84	40	—	3	—	0.72	0.79

Reference edge

Viewed from the motor flange, the reference edge is located on the left side of the linear axis.

2.1.2 KK40 linear axes with aluminium cover

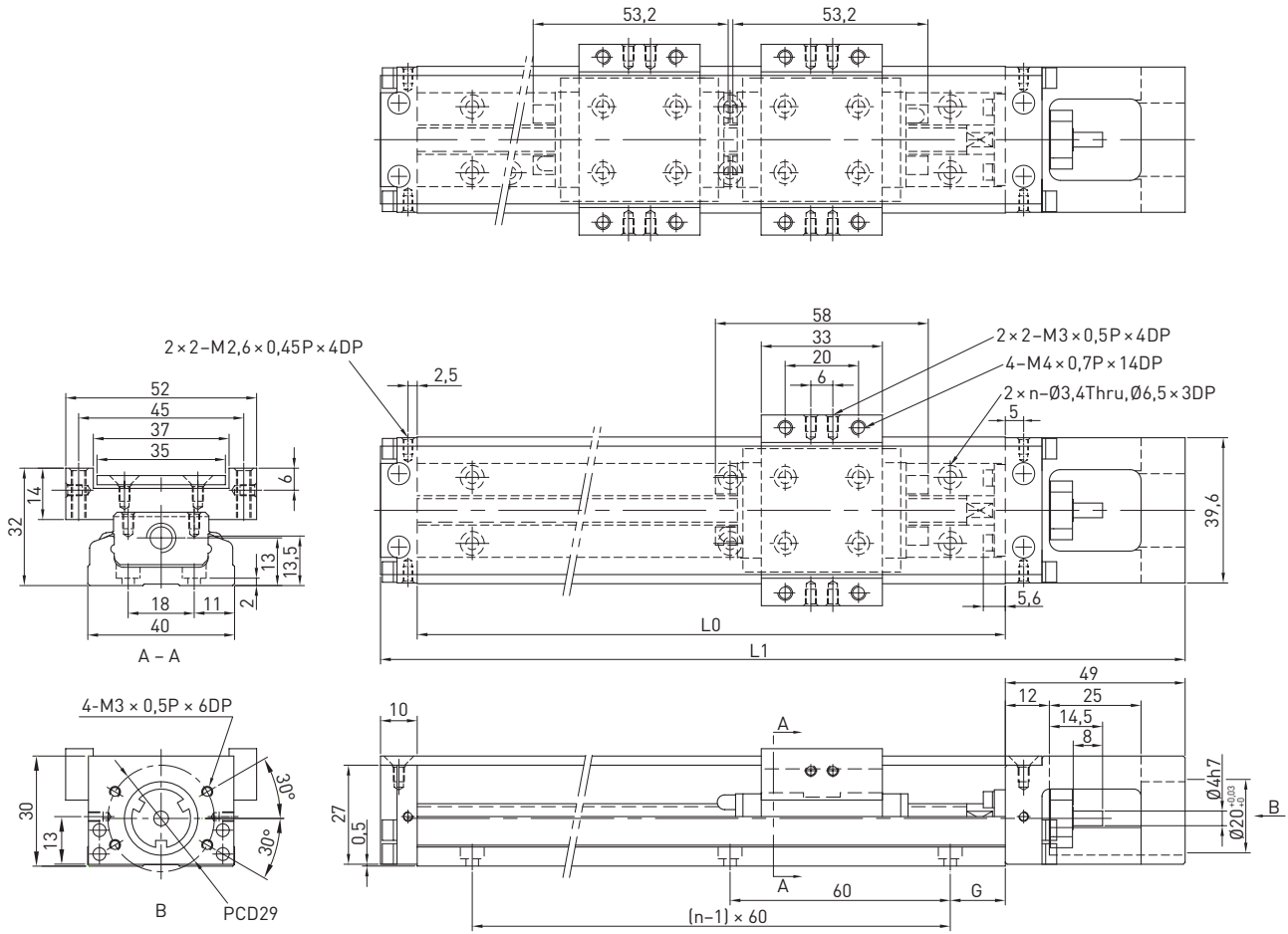

Table 2.2 Dimensions and weights of KK40 linear axes with aluminium cover

Model	lead [mm]	L0 [mm]	L1 [mm]	Maximum stroke [mm]		G [mm]	K [mm]	n	m	Weight [kg]	
				Block A1	Block A2					Block A1	Block A2
KK4001P0100	1	100	159	36	—	20	—	2	—	0.55	—
KK4001P0150	1	150	209	86	34	15	—	3	—	0.68	0.76
KK4001P0200	1	200	259	136	84	40	—	3	—	0.82	0.89

Reference edge

Viewed from the motor flange, the reference edge is located on the left side of the linear axis.

KK Linear Axes

KK40, KK50

2.1.3 KK40 adapter flanges

Motor adapter flange F0

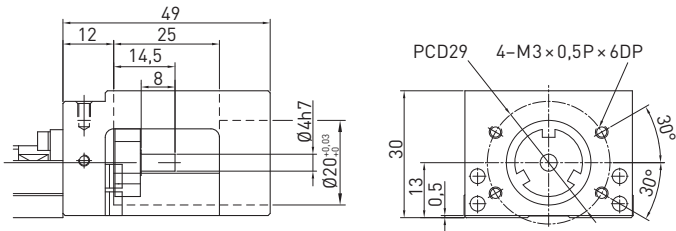

Motor adapter flange F1

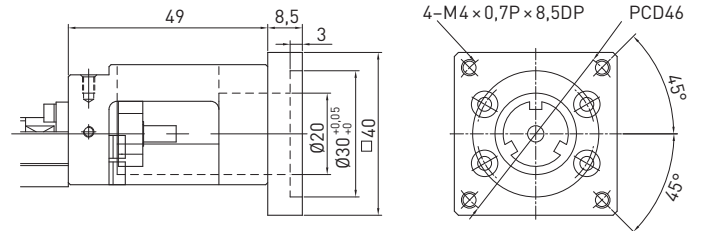

Motor adapter flange F2

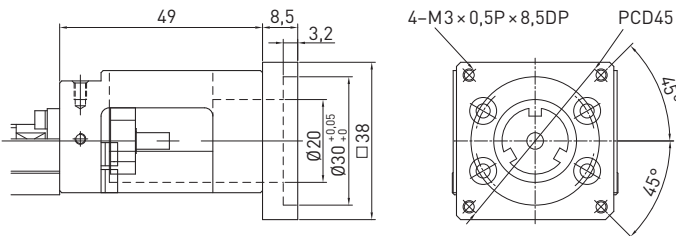

Motor adapter flange F3

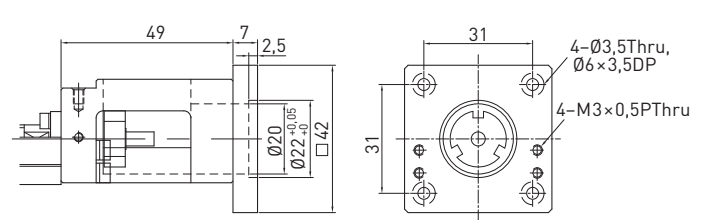

Motor adapter flange H0

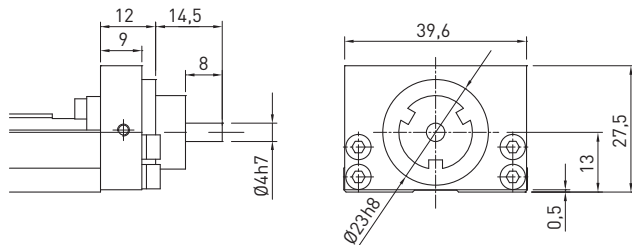

2.2 KK50

2.2.1 KK50 linear axes without cover

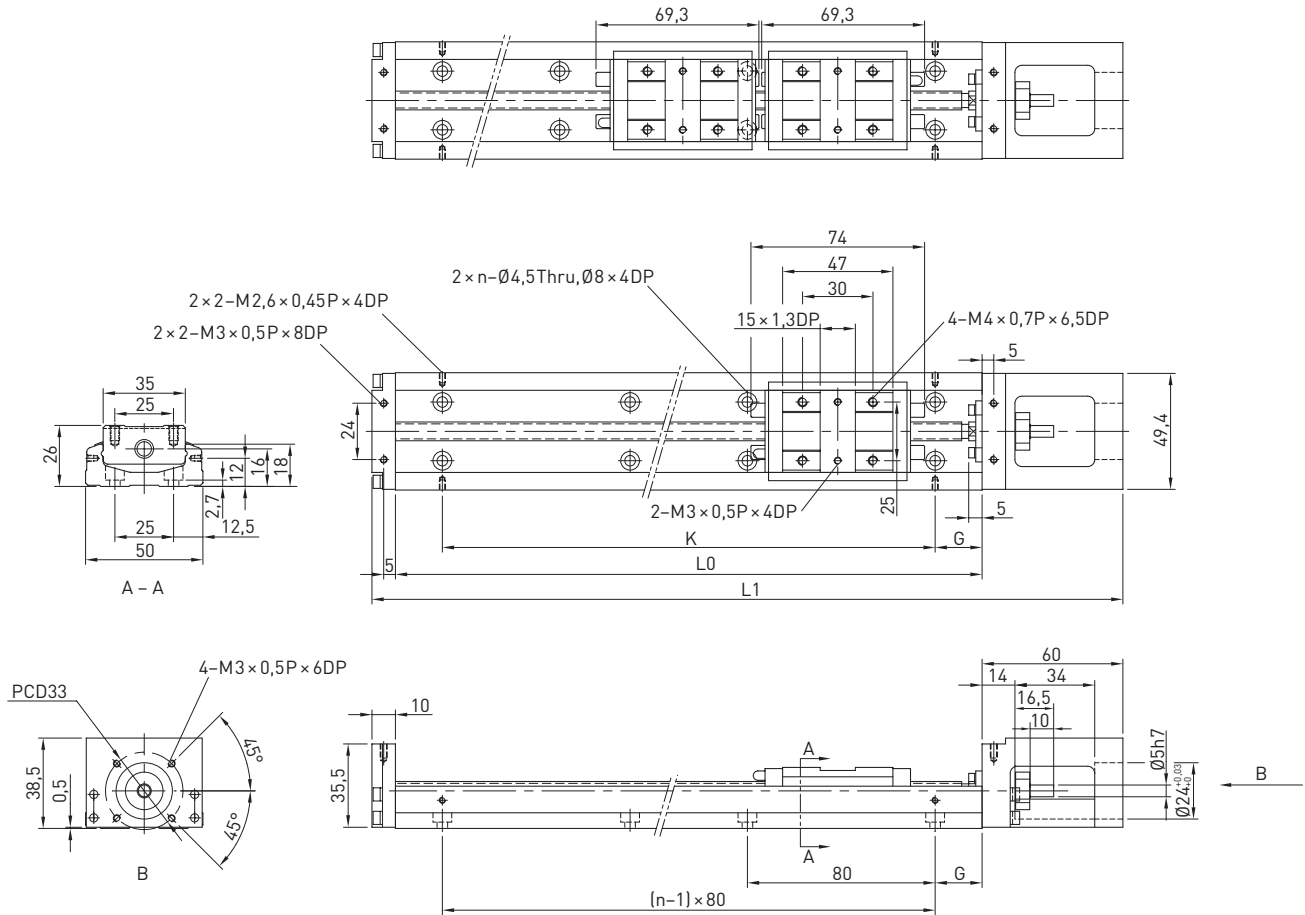

Table 2.3 Dimensions and weights of KK50 linear axes without cover

Model	lead [mm]	L0 [mm]	L1 [mm]	Maximum stroke [mm]		G [mm]	K [mm]	n	m	Weight [kg]	
				Block A1	Block A2					Block A1	Block A2
KK5002P0150	2	150	220	70	—	35	80	2	—	1.0	—
KK5002P0200	2	200	270	120	55	20	160	3	—	1.2	1.4
KK5002P0250	2	250	320	170	105	45	160	3	—	1.4	1.6
KK5002P0300	2	300	370	220	155	30	240	4	—	1.6	1.8

Reference edge

Viewed from the motor flange, the reference edge is located on the left side of the linear axis.

KK Linear Axes

KK50

2.2.2 KK50 linear axes with aluminium cover

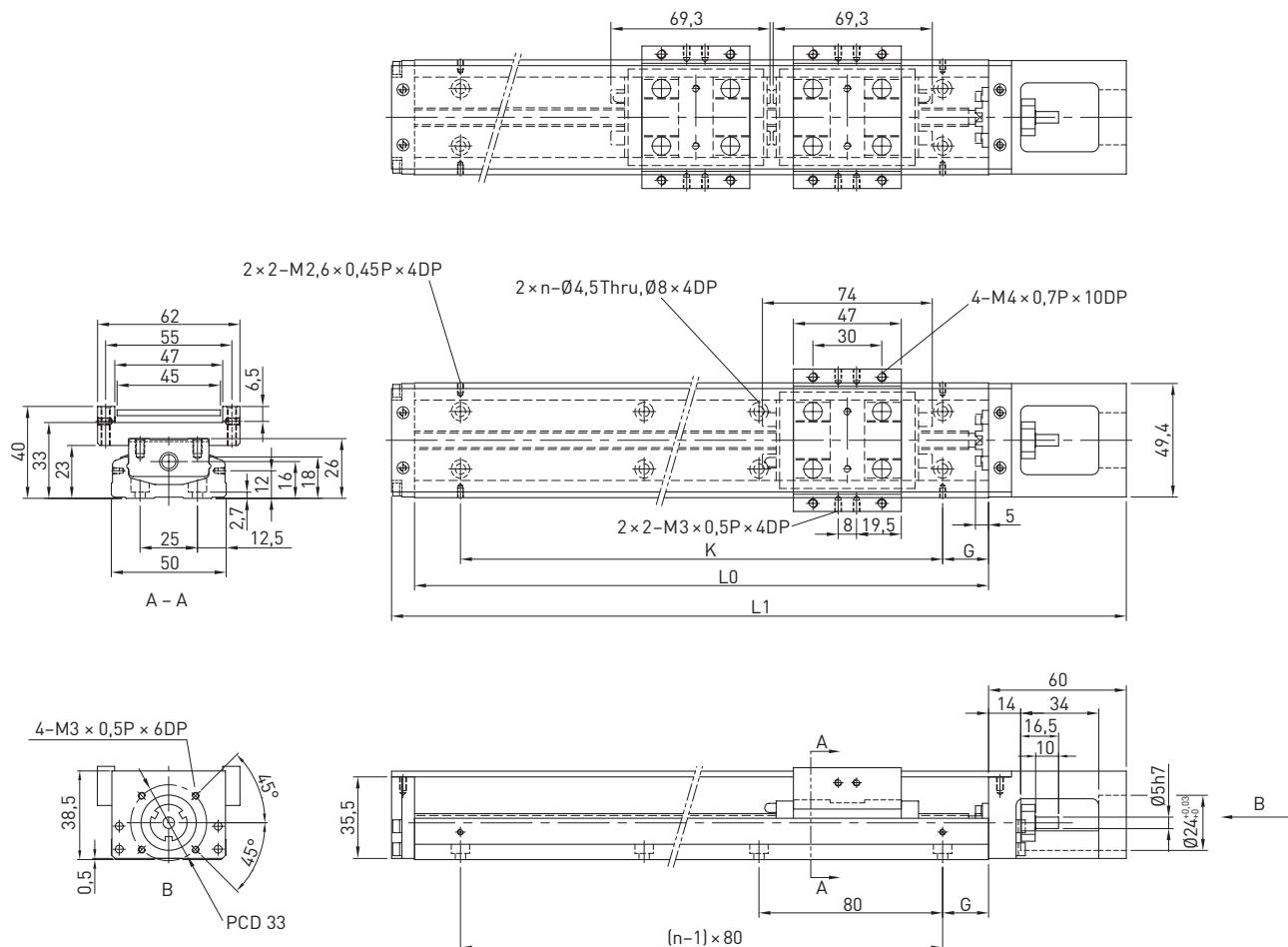

Table 2.4 Dimensions and weights of KK50 linear axes with aluminium cover

Model	lead [mm]	L0 [mm]	L1 [mm]	Maximum stroke [mm]		G [mm]	K [mm]	n	m	Weight [kg]	
				Block A1	Block A2					Block A1	Block A2
KK5002P0150	2	150	220	70	—	35	80	2	—	1.1	—
KK5002P0200	2	200	270	120	55	20	160	3	—	1.3	1.5
KK5002P0250	2	250	320	170	105	45	160	3	—	1.6	1.8
KK5002P0300	2	300	370	220	155	30	240	4	—	1.8	2.0

Reference edge

Viewed from the motor flange, the reference edge is located on the left side of the linear axis.

2.2.3 KK50 adapter flanges

Motor adapter flange F0

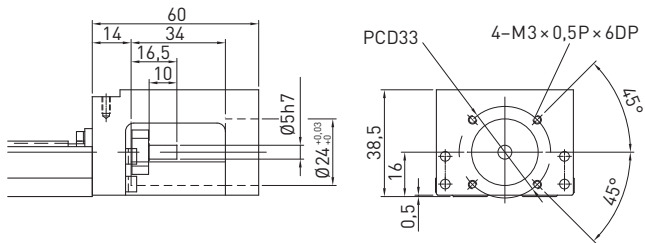

Motor adapter flange F1

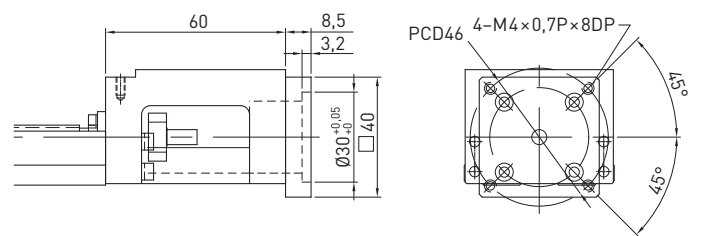

Motor adapter flange F2

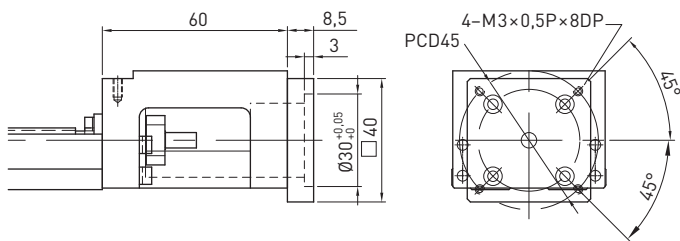

Motor adapter flange F3

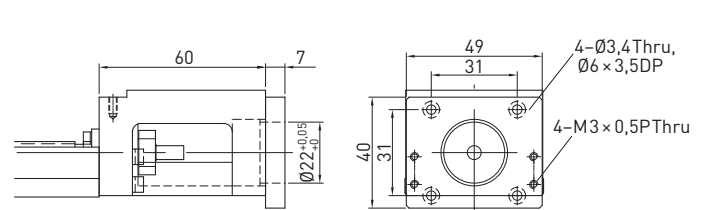

Motor adapter flange F4

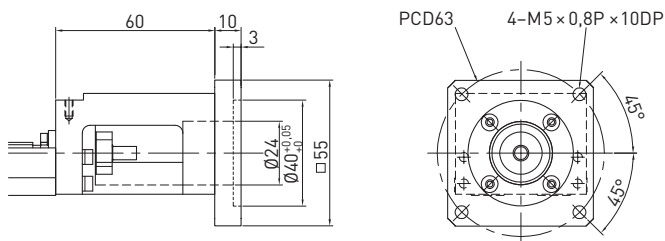

Motor adapter flange F5

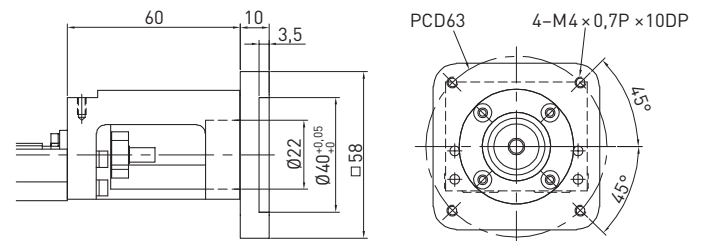

Motor adapter flange F6

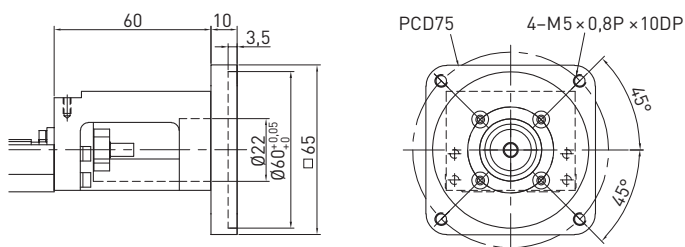

Motor adapter flange F7

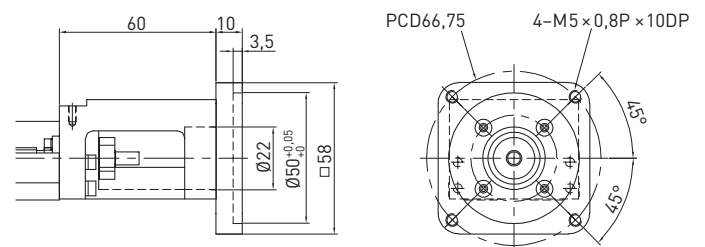

Motor adapter flange H0

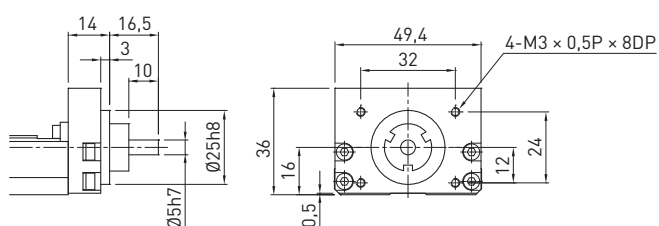

KK Linear Axes

KK60

2.3 KK60

2.3.1 KK60 linear axes without cover, standard block

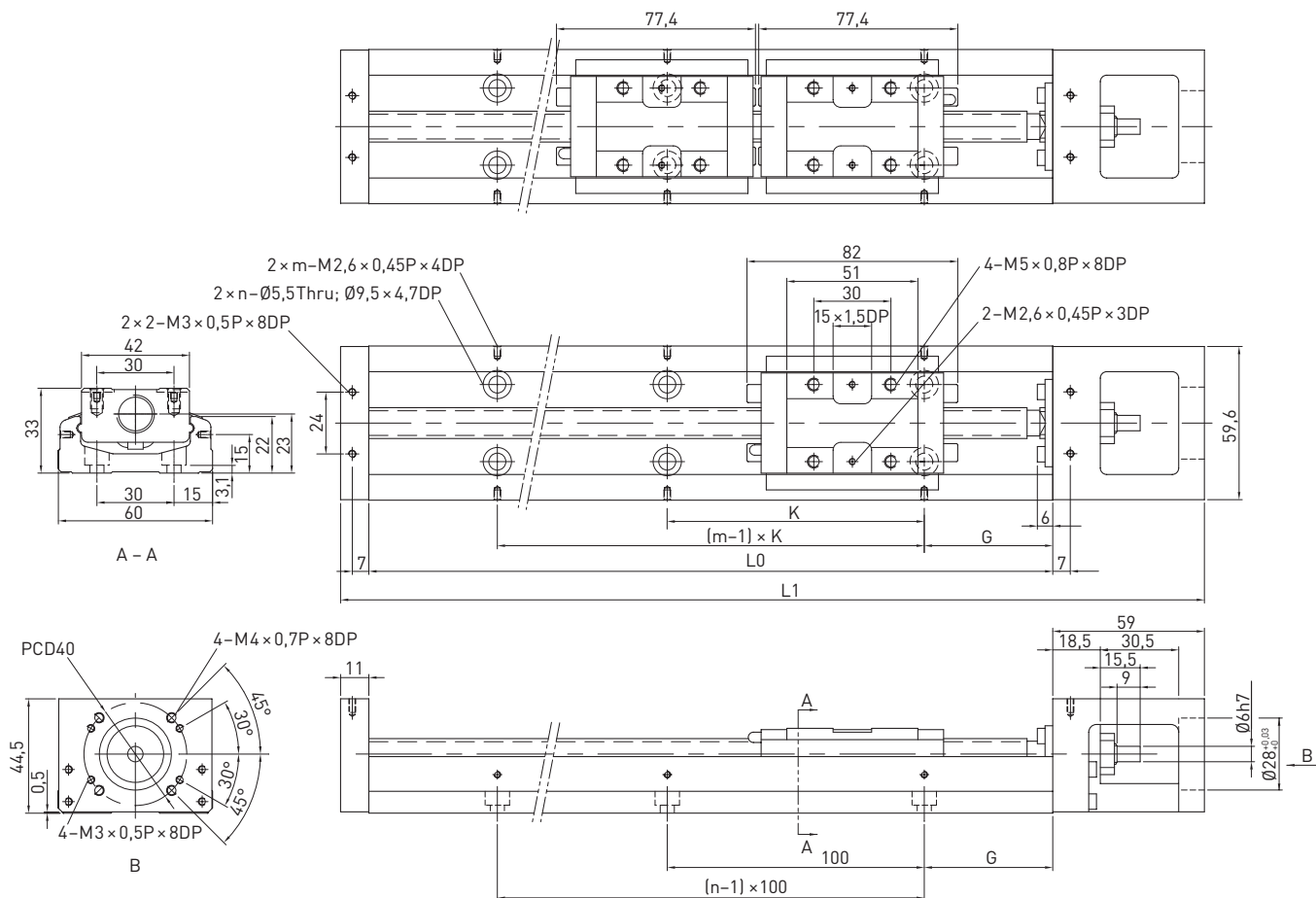

Table 2.5 Dimensions and weights of KK60 linear axes without cover, standard block

Model	lead [mm]	L0 [mm]	L1 [mm]	Maximum stroke [mm]		G [mm]	K [mm]	n	m	Weight [kg]	
				Block A1	Block A2					Block A1	Block A2
KK6005P0150	5	150	220	60	—	25	100	2	2	1.5	—
KK6005P0200	5	200	270	110	—	50	100	2	2	1.8	—
KK6005P0300	5	300	370	210	135	50	200	3	2	2.4	2.7
KK6005P0400	5	400	470	310	235	50	100	4	4	3.0	3.3
KK6005P0500	5	500	570	410	335	50	200	5	3	3.6	3.9
KK6005P0600	5	600	670	510	435	50	100	6	6	4.2	4.6
KK6010P0150	10	150	220	60	—	25	100	2	2	1.5	—
KK6010P0200	10	200	270	110	—	50	100	2	2	1.8	—
KK6010P0300	10	300	370	210	135	50	200	3	2	2.4	2.7
KK6010P0400	10	400	470	310	235	50	100	4	4	3.0	3.3
KK6010P0500	10	500	570	410	335	50	200	5	3	3.6	3.9
KK6010P0600	10	600	670	510	435	50	100	6	6	4.2	4.6

Reference edge

Viewed from the motor flange, the reference edge is located on the left side of the linear axis.

2.3.2 KK60 linear axis without cover, short block

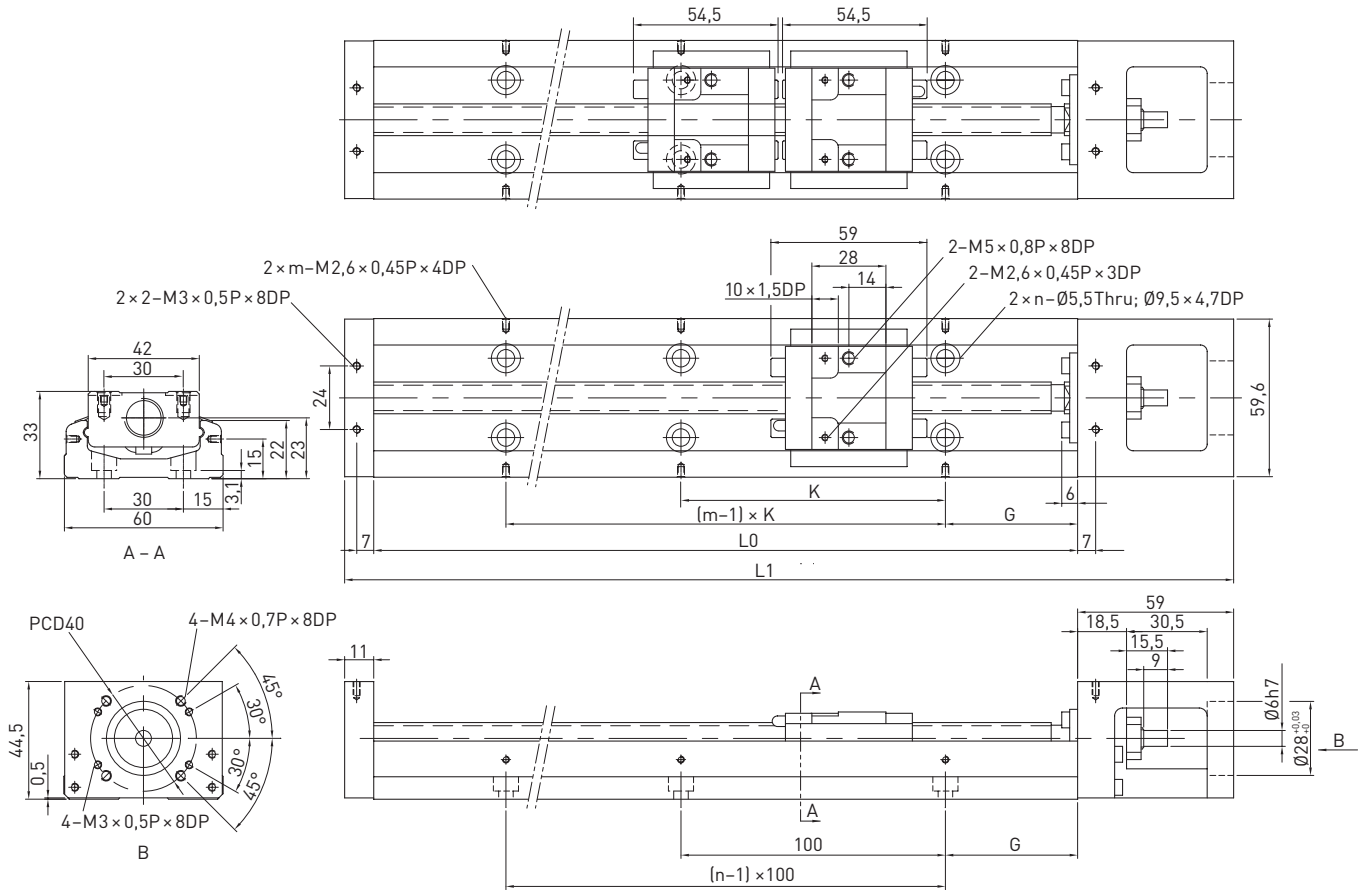

Table 2.6 Dimensions and weight of KK60 linear axes, short block

Model	lead [mm]	L0 [mm]	L1 [mm]	Maximum stroke [mm]		G [mm]	K [mm]	n	m	Weight [kg]	
				Block S1	Block S2					Block S1	Block S2
KK6005P0150	5	150	220	85	34	25	100	2	2	1.4	1.6
KK6005P0200	5	200	270	135	84	50	100	2	2	1.7	1.9
KK6005P0300	5	300	370	235	184	50	200	3	2	2.3	2.5
KK6005P0400	5	400	470	335	284	50	100	4	4	2.9	3.1
KK6005P0500	5	500	570	435	384	50	200	5	3	3.5	3.7
KK6005P0600	5	600	670	535	484	50	100	6	6	4.1	4.3
KK6010P0150	10	150	220	85	34	25	100	2	2	1.4	1.6
KK6010P0200	10	200	270	135	84	50	100	2	2	1.7	1.9
KK6010P0300	10	300	370	235	184	50	200	3	2	2.3	2.5
KK6010P0400	10	400	470	335	284	50	100	4	4	2.9	3.1
KK6010P0500	10	500	570	435	384	50	200	5	3	3.5	3.7
KK6010P0600	10	600	670	535	484	50	100	6	6	4.1	4.3

Reference edge

Viewed from the motor flange, the reference edge is located on the left side of the linear axis.

KK Linear Axes

KK60

2.3.3 KK60 linear axes with aluminium cover, standard block

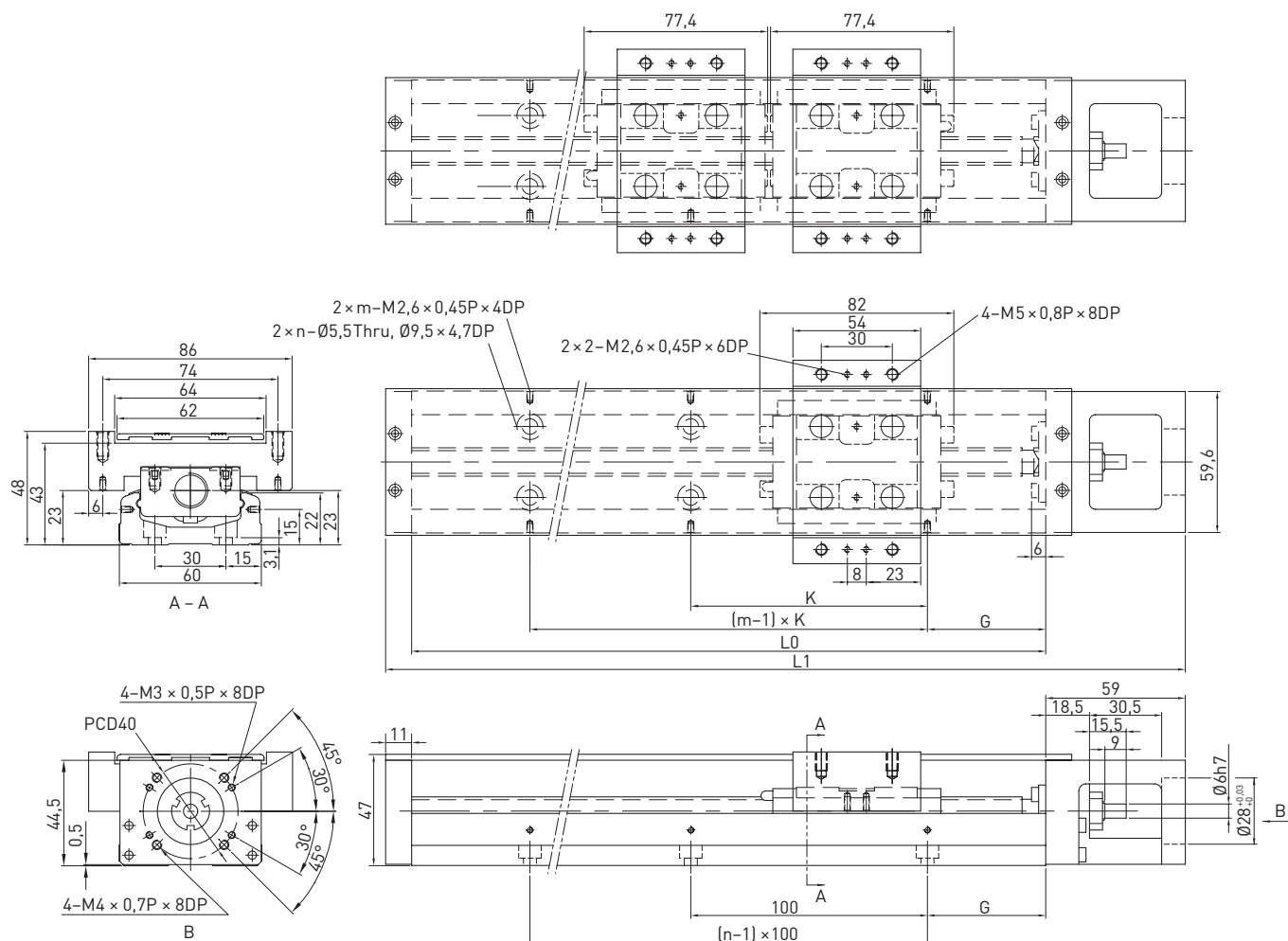

Table 2.7 Dimension and weights of KK60 linear axes with aluminium cover, standard block

Model	lead [mm]	L0 [mm]	L1 [mm]	Maximum stroke [mm]		G [mm]	K [mm]	n	m	Weight [kg]	
				Block A1	Block A2					Block A1	Block A2
KK6005P0150	5	150	220	60	—	25	100	2	2	1.7	—
KK6005P0200	5	200	270	110	—	50	100	2	2	2.1	—
KK6005P0300	5	300	370	210	135	50	200	3	2	2.7	3.0
KK6005P0400	5	400	470	310	235	50	100	4	4	3.3	3.6
KK6005P0500	5	500	570	410	335	50	200	5	3	3.9	4.2
KK6005P0600	5	600	670	510	435	50	100	6	6	4.4	5.0
KK6010P0150	10	150	220	60	—	25	100	2	2	1.7	—
KK6010P0200	10	200	270	110	—	50	100	2	2	2.1	—
KK6010P0300	10	300	370	210	135	50	200	3	2	2.7	3.0
KK6010P0400	10	400	470	310	235	50	100	4	4	3.3	3.6
KK6010P0500	10	500	570	410	335	50	200	5	3	3.9	4.2
KK6010P0600	10	600	670	510	435	50	100	6	6	4.4	5.0

Reference edge

Viewed from the motor flange, the reference edge is located on the left side of the linear axis.

2.3.4 KK60 linear axes with aluminium cover, short block

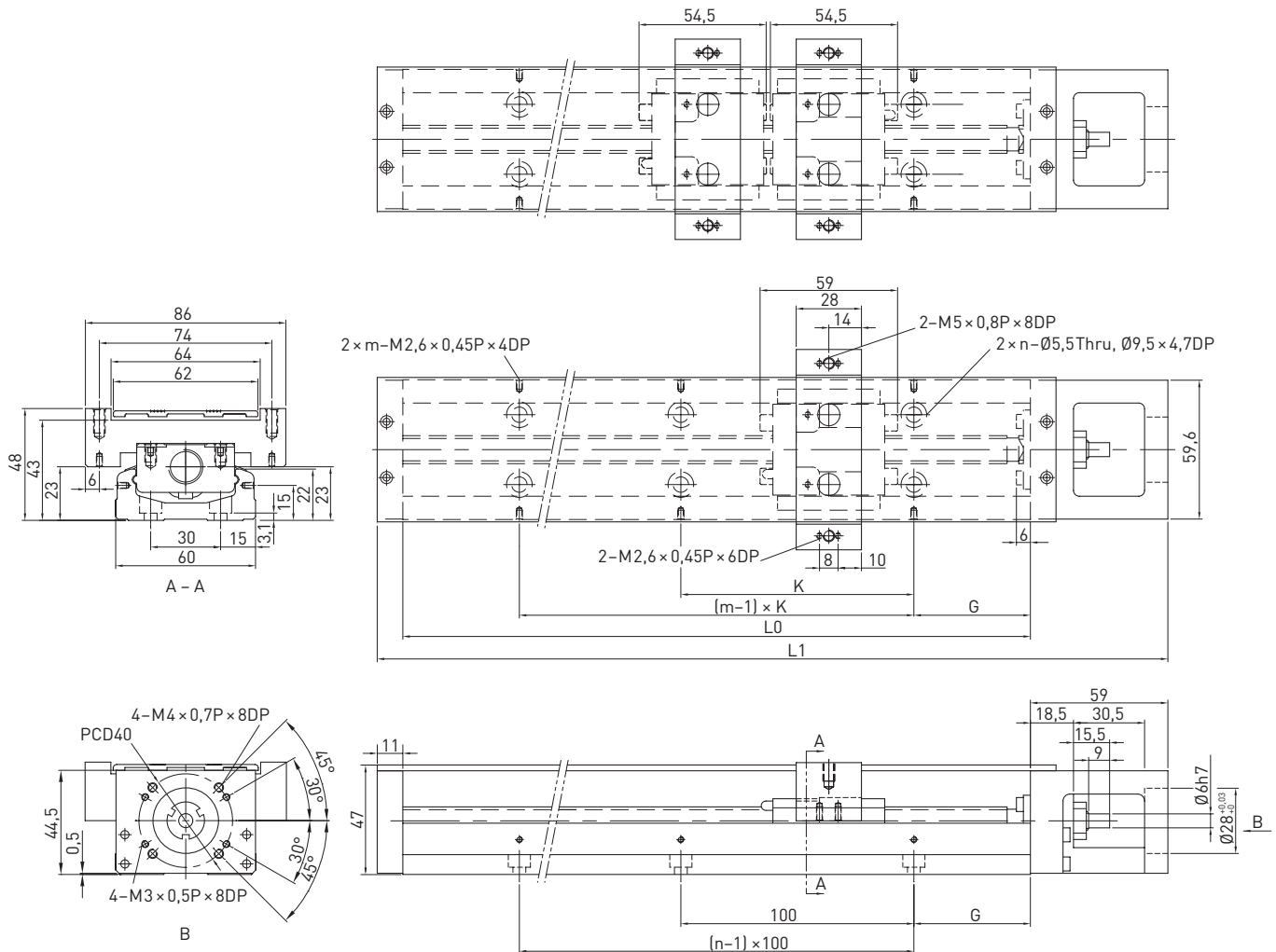

Table 2.8 Dimension and weights of KK60 linear axes with aluminium cover, short block

Model	lead [mm]	L0 [mm]	L1 [mm]	Maximum stroke [mm]		G [mm]	K [mm]	n	m	Weight [kg]	
				Block S1	Block S2					Block S1	Block S2
KK6005P0150	5	150	220	85	34	25	100	2	2	1.60	1.80
KK6005P0200	5	200	270	135	84	50	100	2	2	1.90	2.10
KK6005P0300	5	300	370	235	184	50	200	3	2	2.50	2.70
KK6005P0400	5	400	470	335	284	50	100	4	4	3.10	3.30
KK6005P0500	5	500	570	435	384	50	200	5	3	3.70	3.90
KK6005P0600	5	600	670	535	484	50	100	6	6	4.40	4.60
KK6010P0150	10	150	220	85	34	25	100	2	2	1.60	1.80
KK6010P0200	10	200	270	135	84	50	100	2	2	1.90	2.10
KK6010P0300	10	300	370	235	184	50	200	3	2	2.50	2.70
KK6010P0400	10	400	470	335	284	50	100	4	4	3.10	3.30
KK6010P0500	10	500	570	435	384	50	200	5	3	3.70	3.90
KK6010P0600	10	600	670	535	484	50	100	6	6	4.40	4.60

Reference edge

Viewed from the motor flange, the reference edge is located on the left side of the linear axis.

KK Linear Axes

KK60

2.3.5 KK60 linear axes with bellow cover

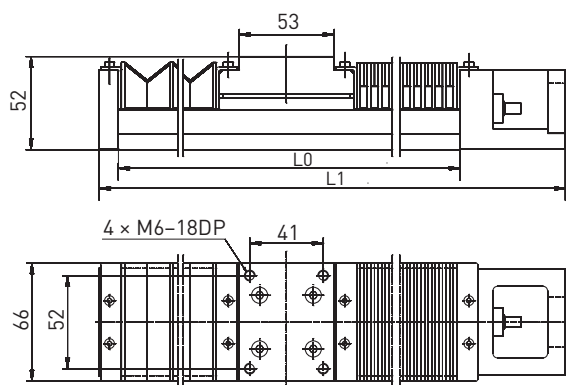
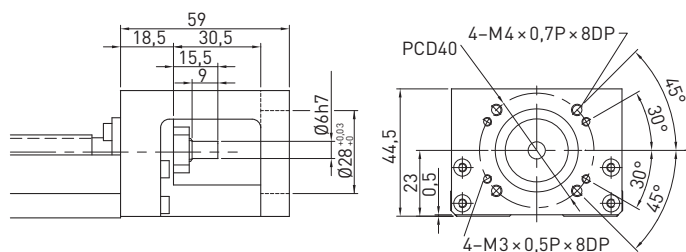

Table 2.9 Dimension and weights of KK60 linear axes with bellow cover

Model	Lead [mm]	L0 [mm]	L1 [mm]	Maximum stroke [mm]	Weight [kg]
KK6005P0150	5	150	220	45	1.7
KK6005P0200	5	200	270	77	2.1
KK6005P0300	5	300	370	151	2.7
KK6005P0400	5	400	470	230	3.3
KK6005P0500	5	500	570	300	3.9
KK6005P0600	5	600	670	376	4.6
KK6010P0150	10	150	220	45	1.7
KK6010P0200	10	200	270	77	2.1
KK6010P0300	10	300	370	151	2.7
KK6010P0400	10	400	470	230	3.3
KK6010P0500	10	500	570	300	3.9
KK6010P0600	10	600	670	376	4.6

2.3.6 KK60 adapter flanges

Motor adapter flange F0



Motor adapter flange F1

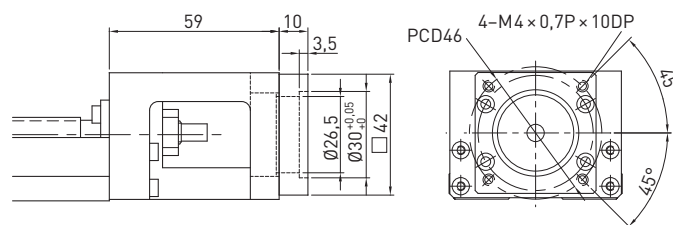

Motor adapter flange F2

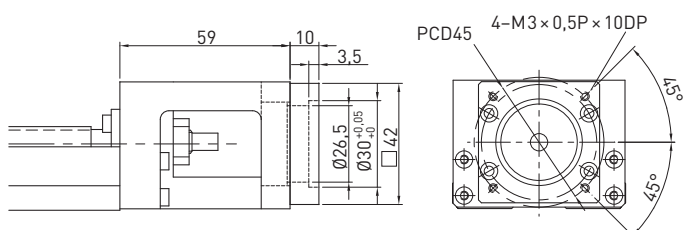

Motor adapter flange F3

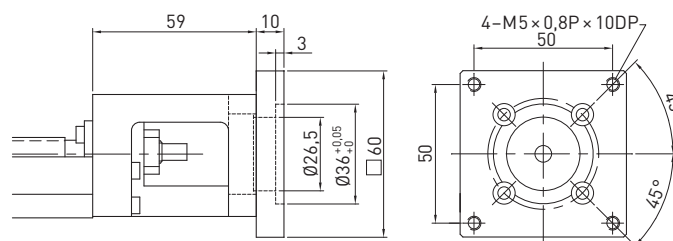

Motor adapter flange F4

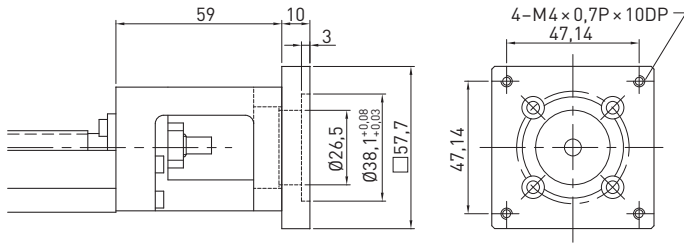

Motor adapter flange F5

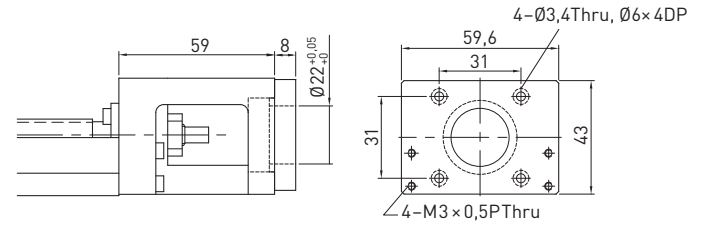

Motor adapter flange F6

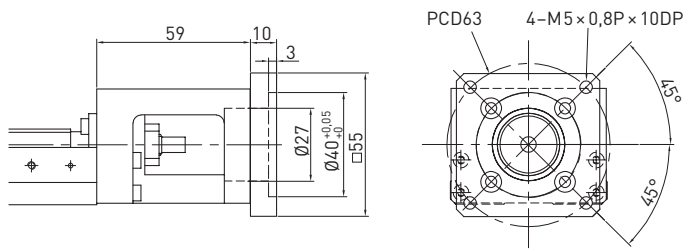

Motor adapter flange F7

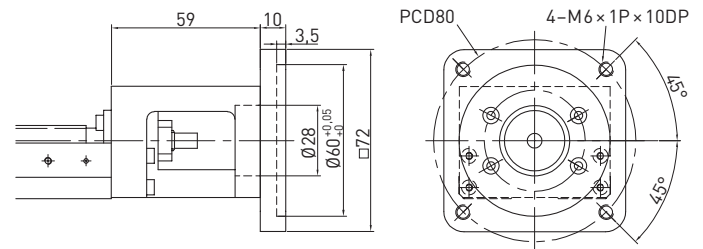

Motor adapter flange F8

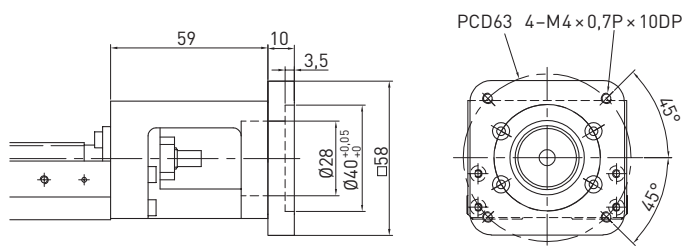

Motor adapter flange F9

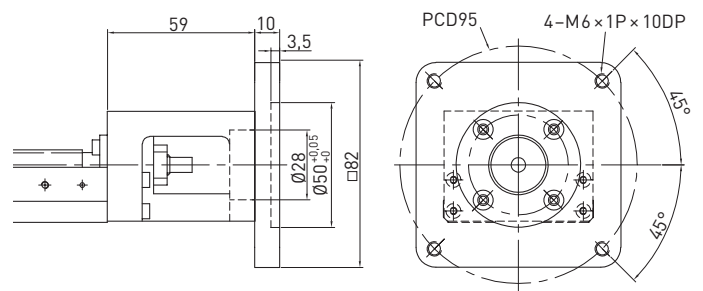

Motor adapter flange F10

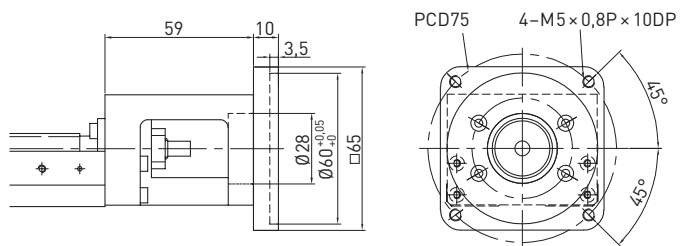

Motor adapter flange F11

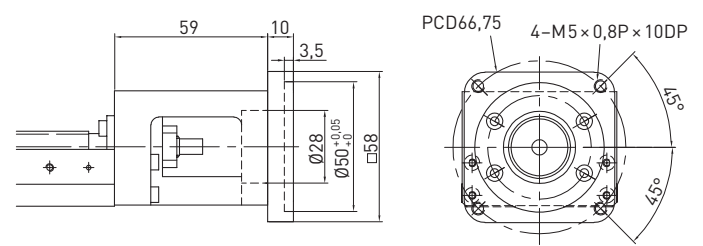

Motor adapter flange H0

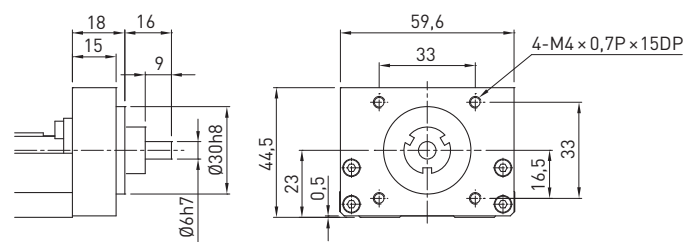

Motor adapter flange H1

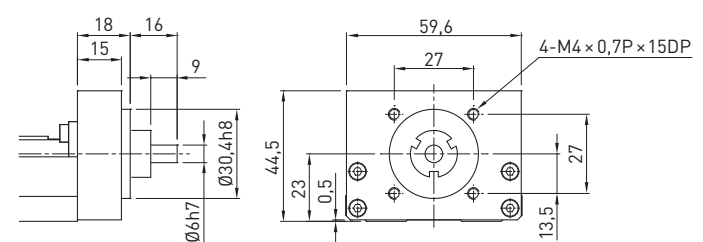

KK Linear Axes

KK86

2.4 KK86

2.4.1 KK86 linear axes without cover, standard block

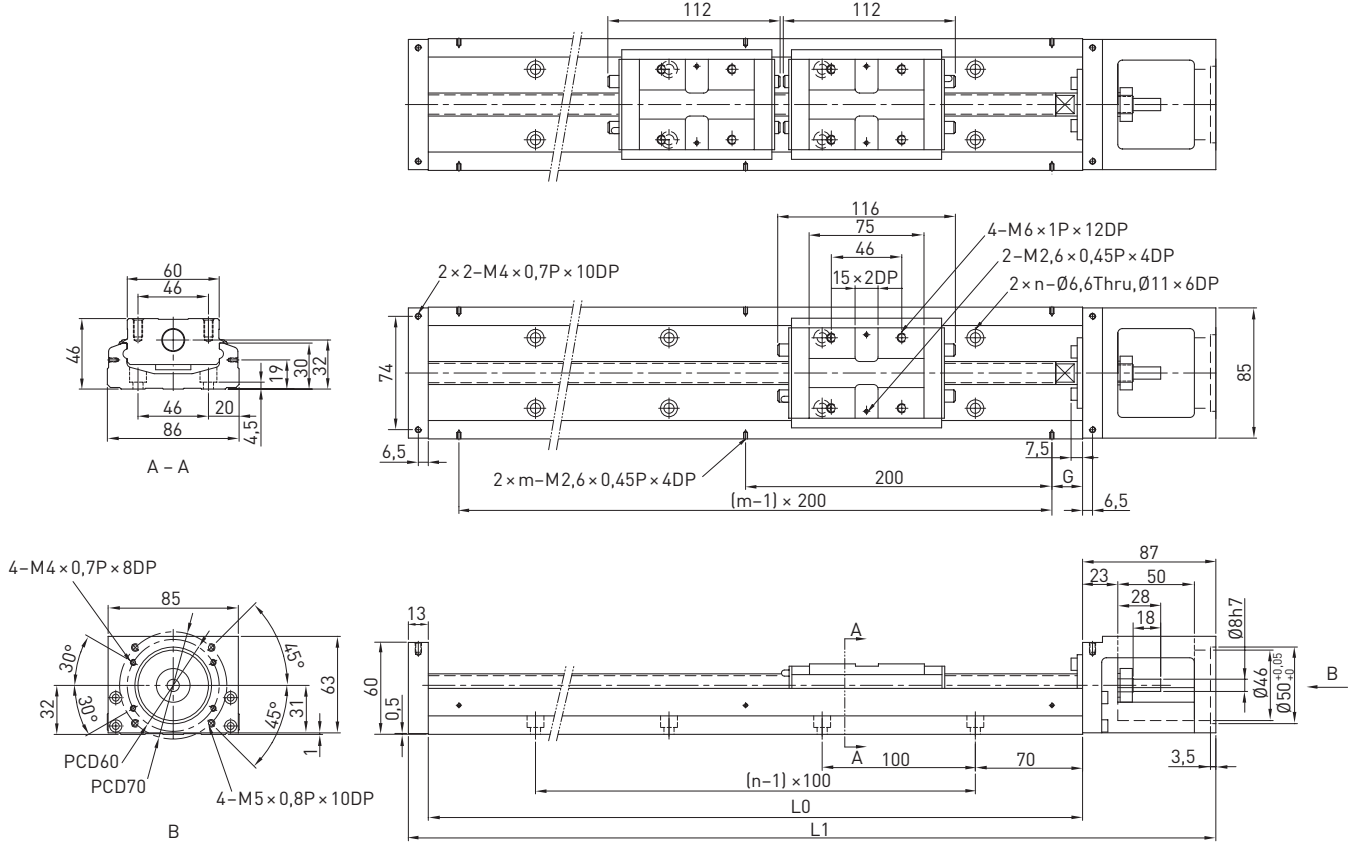

Table 2.10 Dimensions and weights of KK86 linear axes without cover, standard block

Model	lead [mm]	L0 [mm]	L1 [mm]	Maximum stroke [mm]		G [mm]	K [mm]	n	m	Weight [kg]	
				Block A1	Block A2					Block A1	Block A2
KK8610P0340	10	340	440	210	100	70	—	3	2	5.7	6.5
KK8610P0440	10	440	540	310	200	20	—	4	3	6.9	7.7
KK8610P0540	10	540	640	410	300	70	—	5	3	8.0	8.8
KK8610P0640	10	640	740	510	400	20	—	6	4	9.2	10.0
KK8610P0740	10	740	840	610	500	70	—	7	4	10.4	11.2
KK8610P0940	10	940	1040	810	700	70	—	9	5	11.6	12.4
KK8620P0340	20	340	440	210	100	70	—	3	2	5.7	6.5
KK8620P0440	20	440	540	310	200	20	—	4	3	6.9	7.7
KK8620P0540	20	540	640	410	300	70	—	5	3	8.0	8.8
KK8620P0640	20	640	740	510	400	20	—	6	4	9.2	10.0
KK8620P0740	20	740	840	610	500	70	—	7	4	10.4	11.2
KK8620P0940	20	940	1040	810	700	70	—	9	5	11.6	12.4

Reference edge

Viewed from the motor flange, the reference edge is located on the left side of the linear axis.

2.4.2 KK86 linear axes without aluminium cover, short block

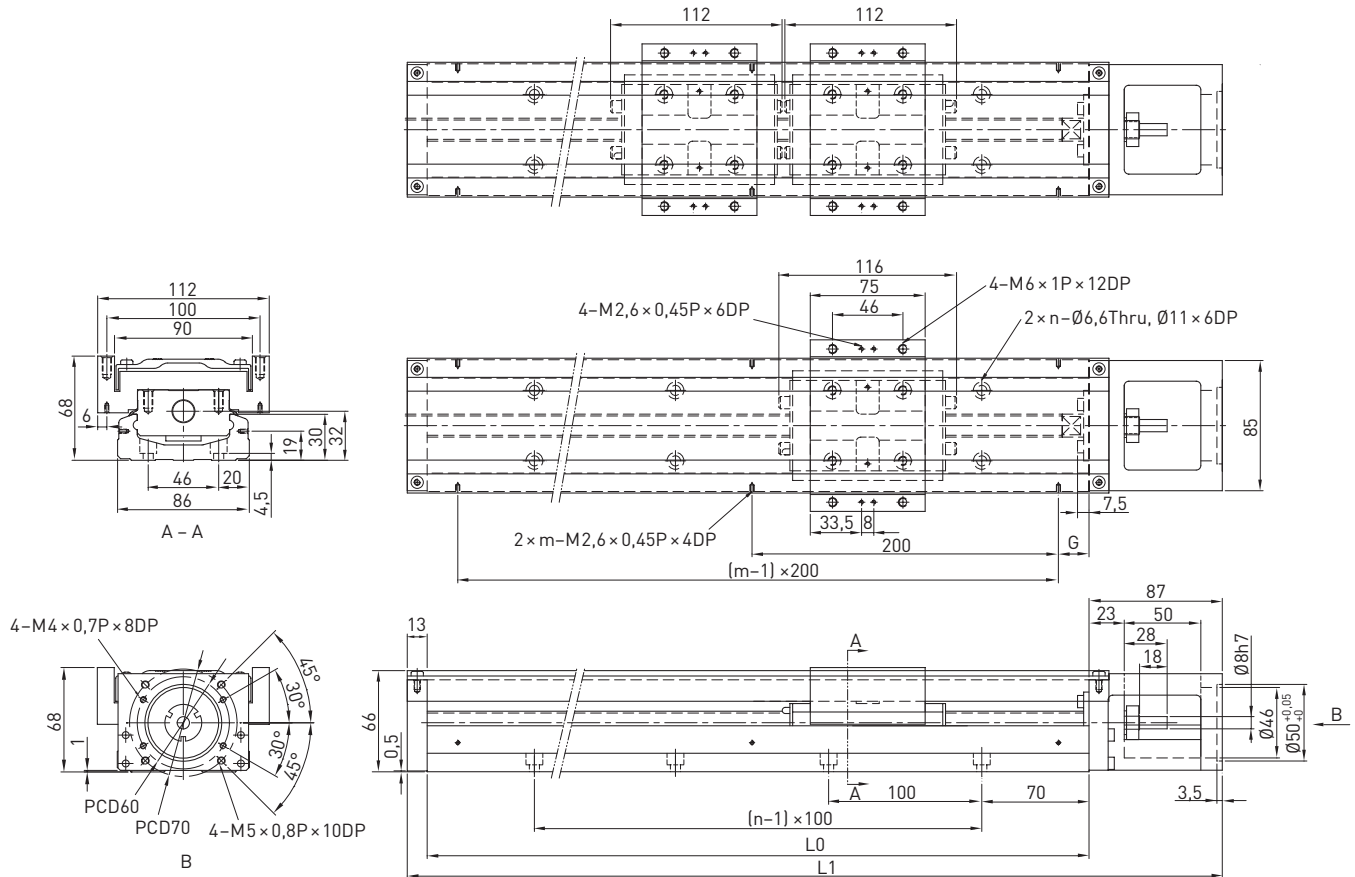

Table 2.11 Dimensions and weights of KK86 linear axes without aluminium cover, short block

Model	lead [mm]	L0 [mm]	L1 [mm]	Maximum stroke [mm]		G [mm]	K [mm]	n	m	Weight [kg]	
				Block S1	Block S2					Block S1	Block S2
KK8610P0340	10	340	440	246	170	70	—	3	2	5.4	5.9
KK8610P0440	10	440	540	346	270	20	—	4	3	6.6	7.1
KK8610P0540	10	540	640	446	370	70	—	5	3	7.7	8.2
KK8610P0640	10	640	740	546	470	20	—	6	4	8.9	9.4
KK8610P0740	10	740	840	646	570	70	—	7	4	10.1	10.6
KK8610P0940	10	940	1040	846	770	70	—	9	5	11.3	11.8
KK8620P0340	20	340	440	246	170	70	—	3	2	5.4	5.9
KK8620P0440	20	440	540	346	270	20	—	4	3	6.6	7.1
KK8620P0540	20	540	640	446	370	70	—	5	3	7.7	8.2
KK8620P0640	20	640	740	546	470	20	—	6	4	8.9	9.4
KK8620P0740	20	740	840	646	570	70	—	7	4	10.1	10.6
KK8620P0940	20	940	1040	846	770	70	—	9	5	11.3	11.8

Reference edge

Viewed from the motor flange, the reference edge is located on the left side of the linear axis.

KK Linear Axes

KK86

2.4.3 KK86 linear axes with aluminium cover, standard block

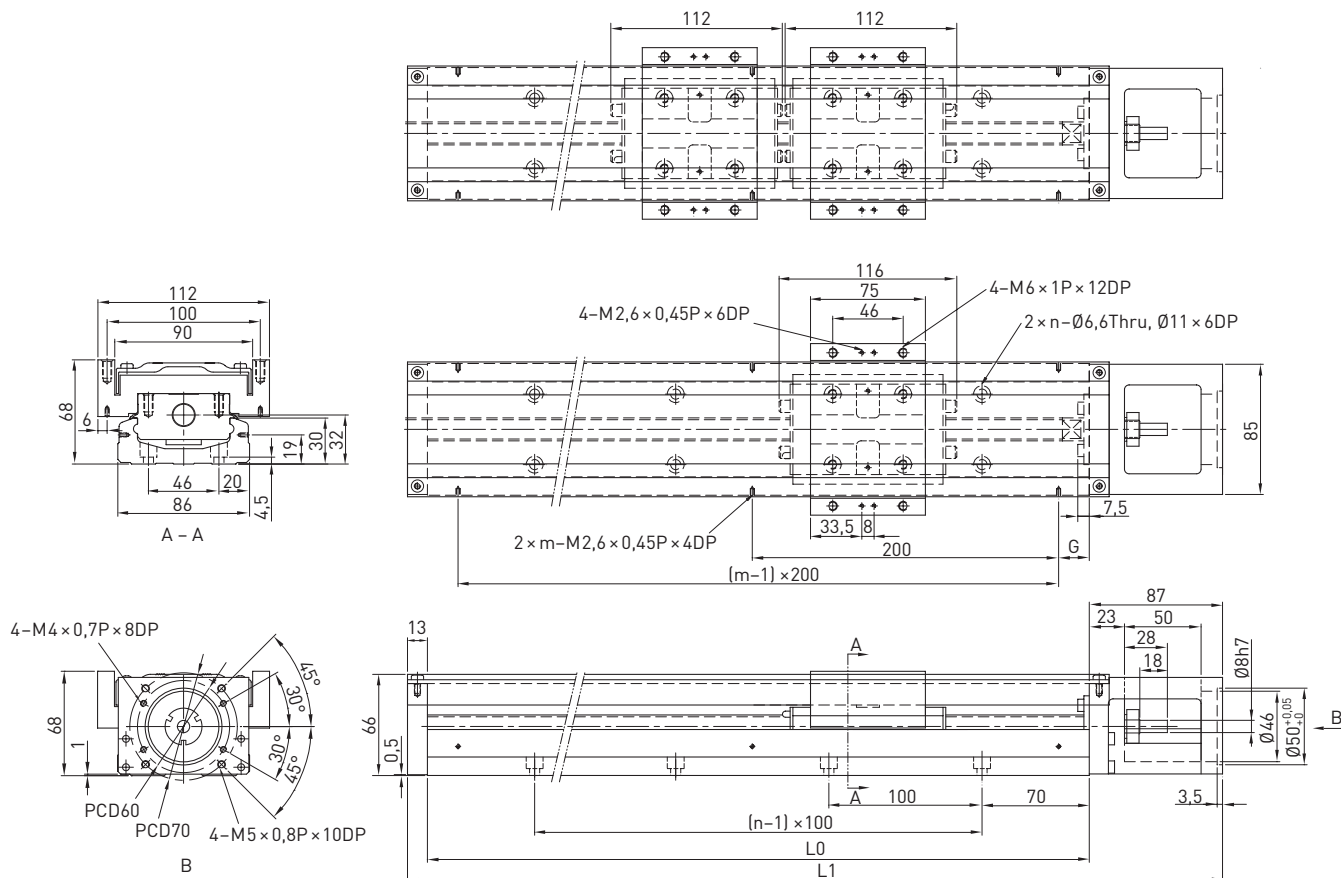

Table 2.12 Dimensions and weights of KK86 linear axes with aluminium cover, standard block

Model	lead [mm]	L0 [mm]	L1 [mm]	Maximum stroke [mm]		G [mm]	K [mm]	n	m	Weight [kg]	
				Block A1	Block A2					Block A1	Block A2
KK8610P0340	10	340	440	210	100	70	—	3	2	6.5	7.3
KK8610P0440	10	440	540	310	200	20	—	4	3	7.8	8.6
KK8610P0540	10	540	640	410	300	70	—	5	3	9.0	9.8
KK8610P0640	10	640	740	510	400	20	—	6	4	10.3	11.3
KK8610P0740	10	740	840	610	500	70	—	7	4	11.6	12.4
KK8610P0940	10	940	1040	810	700	70	—	9	5	13.0	13.8
KK8620P0340	20	340	440	210	100	70	—	3	2	6.5	7.3
KK8620P0440	20	440	540	310	200	20	—	4	3	7.8	8.6
KK8620P0540	20	540	640	410	300	70	—	5	3	9.0	9.8
KK8620P0640	20	640	740	510	400	20	—	6	4	10.3	11.3
KK8620P0740	20	740	840	610	500	70	—	7	4	11.6	12.4
KK8620P0940	20	940	1040	810	700	70	—	9	5	13.0	13.8

Reference edge

Viewed from the motor flange, the reference edge is located on the left side of the linear axis.

2.4.4 KK86 linear axes with aluminium cover short block

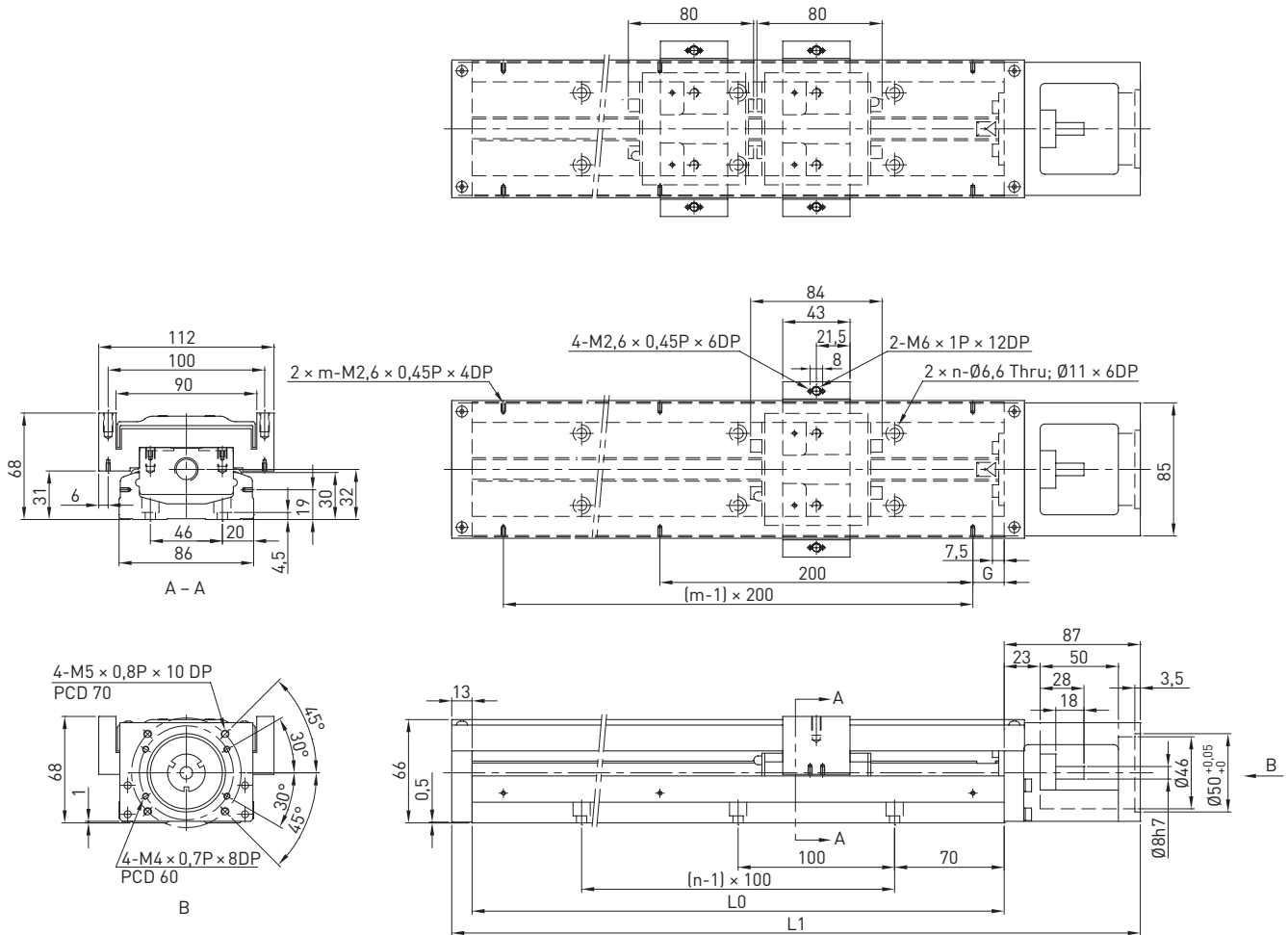

Table 2.13 Dimensions and weights of KK86 linear axes with aluminium cover, short block

Model	lead [mm]	L0 [mm]	L1 [mm]	Maximum stroke [mm]		G [mm]	K [mm]	n	m	Weight [kg]	
				Block S1	Block S2					Block S1	Block S2
KK8610P0340	10	340	440	246	170	70	—	3	2	6.3	7.1
KK8610P0440	10	440	540	346	270	20	—	4	3	7.6	8.4
KK8610P0540	10	540	640	446	370	70	—	5	3	8.8	9.6
KK8610P0640	10	640	740	546	470	20	—	6	4	10.1	11.1
KK8610P0740	10	740	840	646	570	70	—	7	4	11.4	12.2
KK8610P0940	10	940	1040	846	770	70	—	9	5	12.8	13.6
KK8620P0340	20	340	440	246	170	70	—	3	2	6.3	7.1
KK8620P0440	20	440	540	346	270	20	—	4	3	7.6	8.4
KK8620P0540	20	540	640	446	370	70	—	5	3	8.8	9.6
KK8620P0640	20	640	740	546	470	20	—	6	4	10.1	11.1
KK8620P0740	20	740	840	646	570	70	—	7	4	11.4	12.2
KK8620P0940	20	940	1040	846	770	70	—	9	5	12.8	13.6

Reference edge

Viewed from the motor flange, the reference edge is located on the left side of the linear axis.

KK Linear Axes

KK86

2.4.5 KK86 linear axes with bellow cover

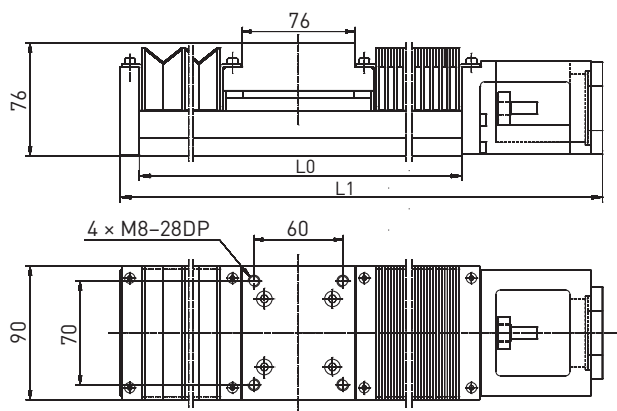
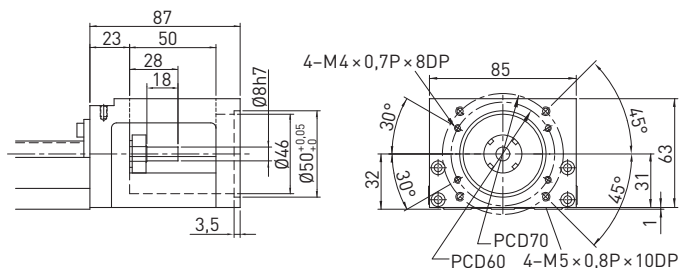

Table 2.14 Dimensions and weights of KK86 linear axes with bellow cover

Model	Lead [mm]	L0 [mm]	L1 [mm]	Maximum stroke [mm]	Weight [kg]
KK8610P0340	10	340	440	174	6.3
KK8610P0440	10	440	540	248	7.6
KK8610P0540	10	540	640	327	8.8
KK8610P0640	10	640	740	410	10.0
KK8610P0740	10	740	840	491	11.3
KK8610P0940	10	940	1040	654	12.7
KK8620P0340	20	340	440	174	6.3
KK8620P0440	20	440	540	248	7.6
KK8620P0540	20	540	640	327	8.8
KK8620P0640	20	640	740	410	10.0
KK8620P0740	20	740	840	491	11.3
KK8620P0940	20	940	1040	654	12.7

2.4.6 KK86 adapter flanges

Motor adapter flange F0



Motor adapter flange F1

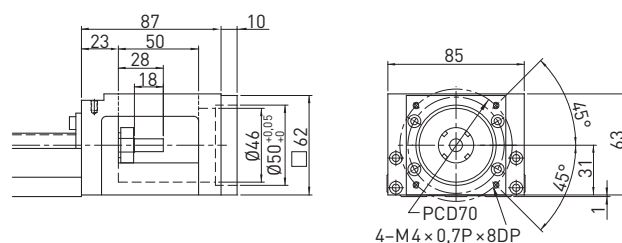

Motor adapter flange F2

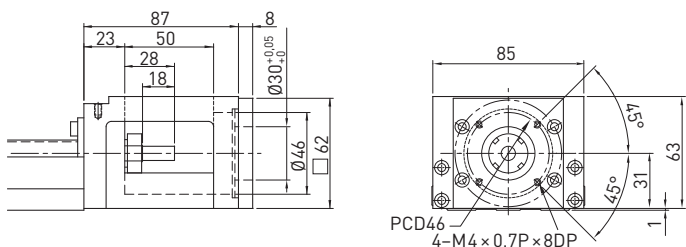

Motor adapter flange F3

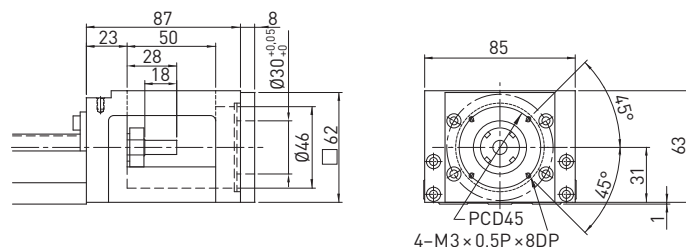

Motor adapter flange F4

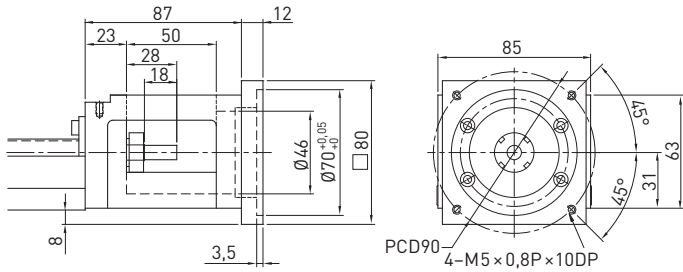

Motor adapter flange F5

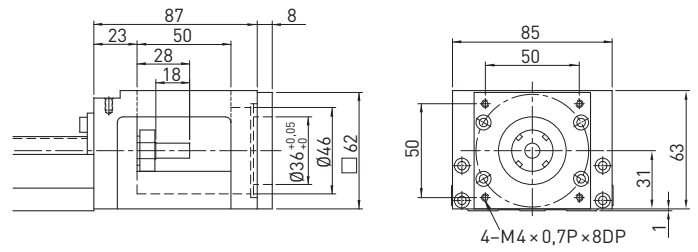

Motor adapter flange F6

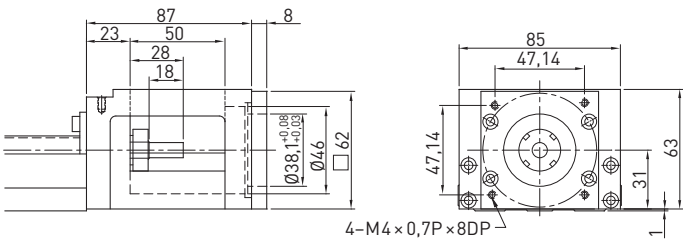

Motor adapter flange F7

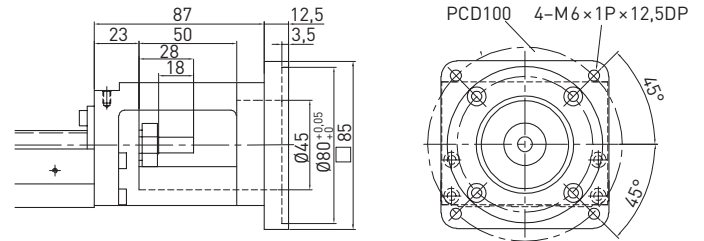

Motor adapter flange F8

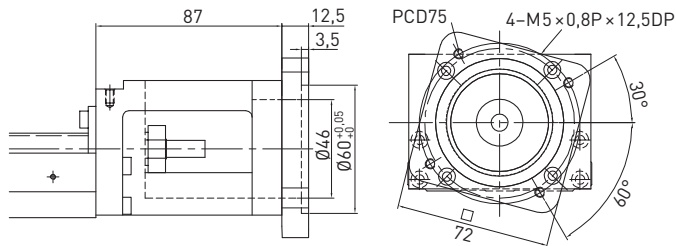

Motor adapter flange F9

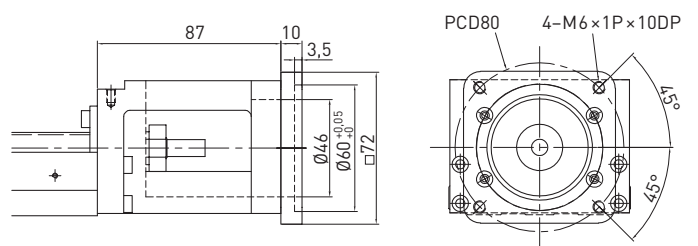

Motor adapter flange F10

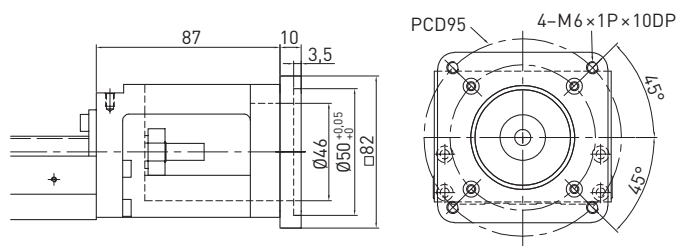

Motor adapter flange H0

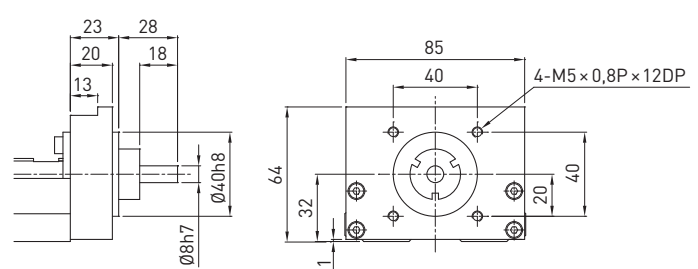

KK Linear Axes

KK100

2.5 KK100

2.5.1 KK100 linear axes without cover

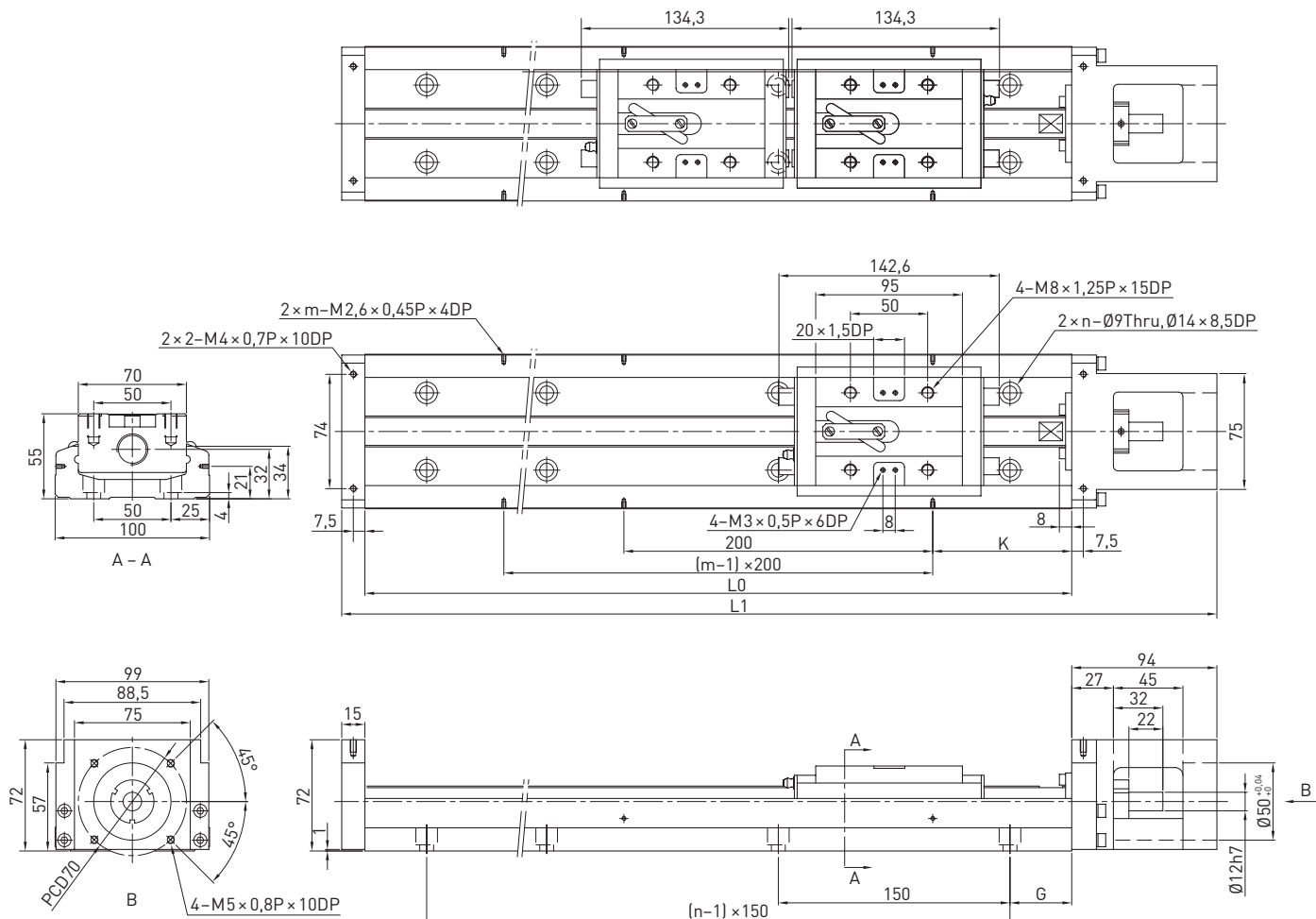

Table 2.15 Dimensions and weights of KK100 linear axes without cover

Model	lead [mm]	L0 [mm]	L1 [mm]	Maximum stroke [mm]		G [mm]	K [mm]	n	m	Weight [kg]	
				Block A1	Block A2					Block A1	Block A2
KK10020P0980	20	980	1089	828	700	40	90	7	5	18.6	20.3
KK10020P1080	20	1080	1189	928	800	15	40	8	6	20.3	22.0
KK10020P1180	20	1180	1289	1028	900	65	90	8	6	22.0	23.7
KK10020P1280	20	1280	1389	1128	1000	40	40	9	7	23.6	25.3
KK10020P1380	20	1380	1489	1228	1100	15	90	10	7	25.3	27.0

Reference edge

Viewed from the motor flange, the reference edge is located on the left side of the linear axis.

2.5.2 KK100 linear axes with aluminium cover

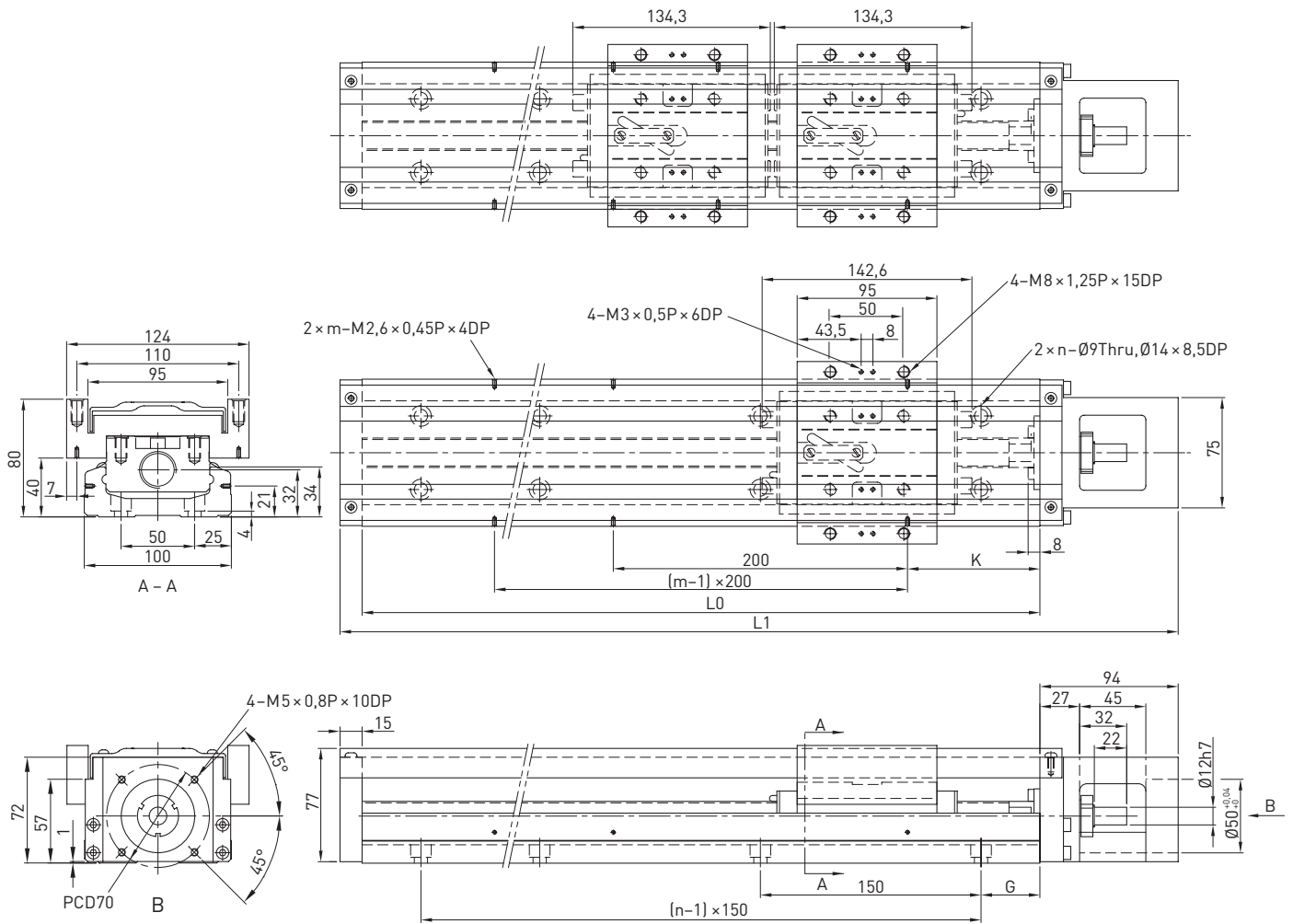

Table 2.16 Dimensions and weights of KK100 linear axes with aluminium cover

Model	lead [mm]	L0 [mm]	L1 [mm]	Maximum stroke [mm]		G [mm]	K [mm]	n	m	Weight [kg]	
				Block A1	Block A2					Block A1	Block A2
KK10020P0980	20	980	1089	828	700	40	90	7	5	20.4	22.1
KK10020P1080	20	1080	1189	928	800	15	40	8	6	22.2	23.9
KK10020P1180	20	1180	1289	1028	900	65	90	8	6	24.0	25.7
KK10020P1280	20	1280	1389	1128	1000	40	40	9	7	25.7	27.4
KK10020P1380	20	1380	1489	1228	1100	15	90	10	7	27.5	29.2

Reference edge

Viewed from the motor flange, the reference edge is located on the left side of the linear axis.

KK Linear Axes

KK100, KK130

2.5.3 KK100 adapter flanges

Motor adapter flange F0

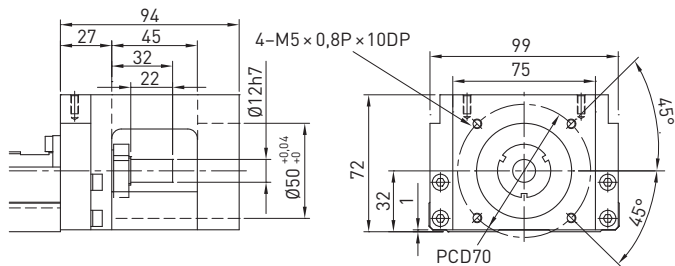

Motor adapter flange F1

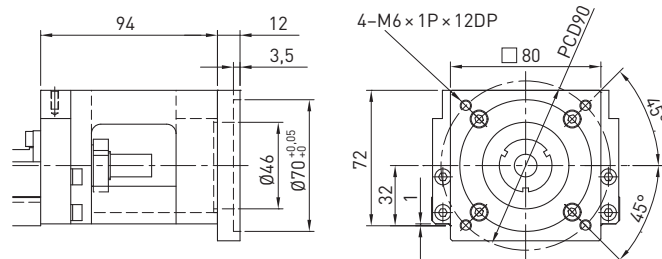

Motor adapter flange F2

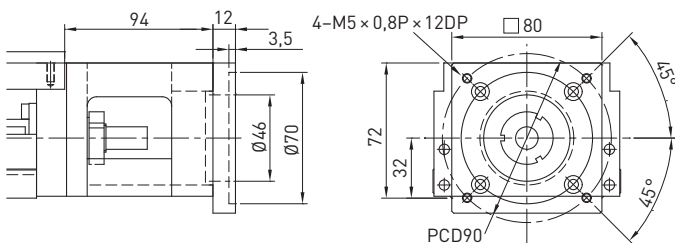

Motor adapter flange F3

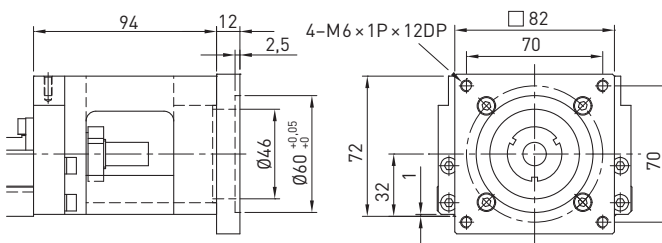

Motor adapter flange F4

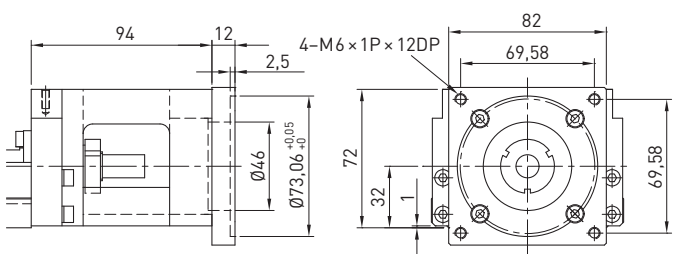

Motor adapter flange F5

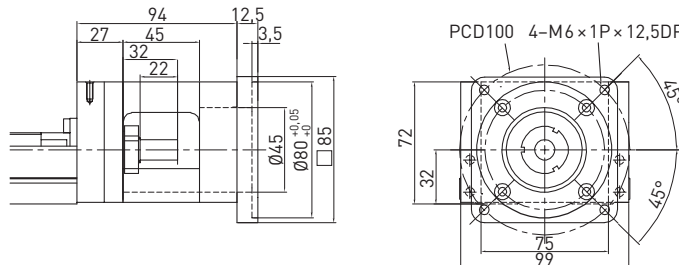

Motor adapter flange F6

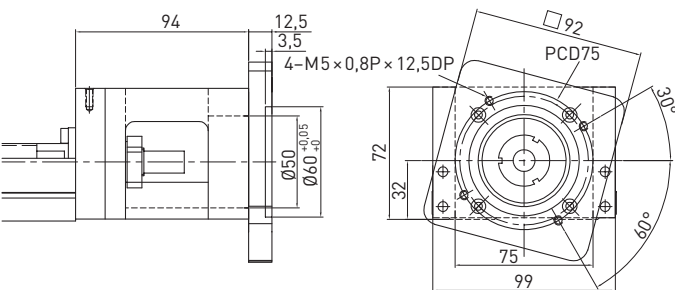

Motor adapter flange F7

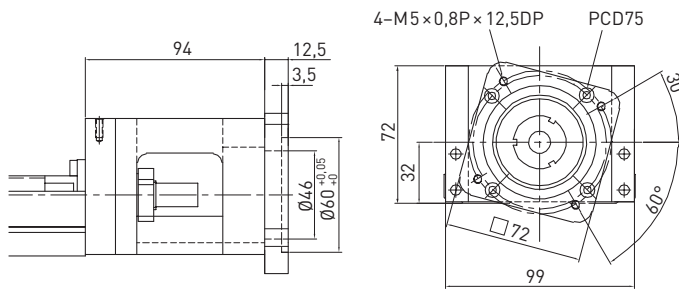

Motor adapter flange H0

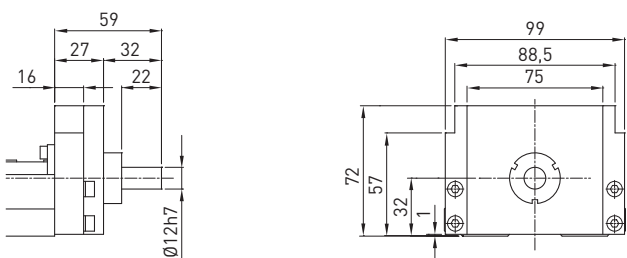

2.6 KK130

2.6.1 KK130 linear axes without aluminium cover

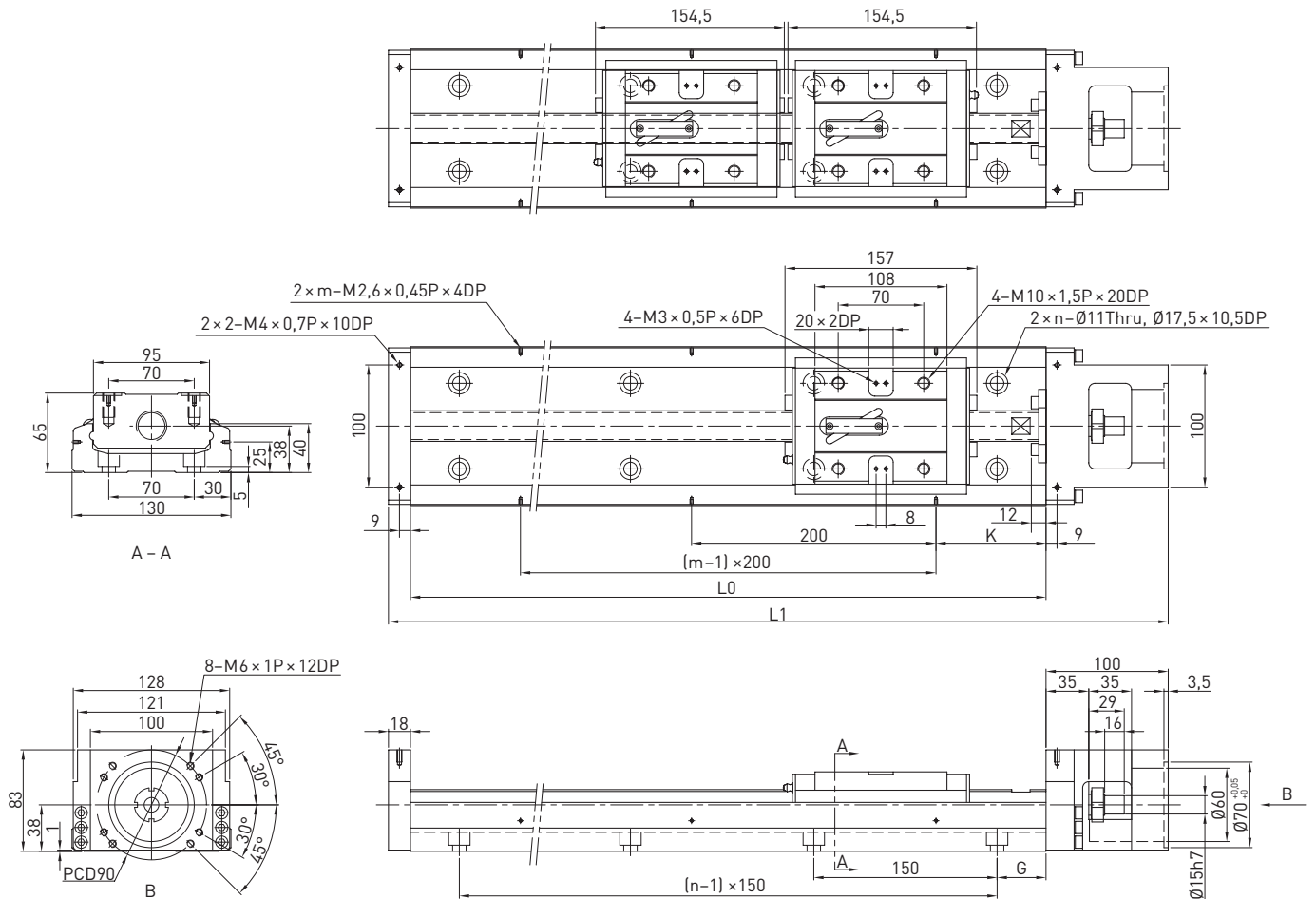

Table 2.17 Dimensions and weights of KK130 linear axes without cover

Model	lead [mm]	L0 [mm]	L1 [mm]	Maximum stroke [mm]		G [mm]	K [mm]	n	m	Weight [kg]	
				Block A1	Block A2					Block A1	Block A2
KK13025P0980	25	980	1098	811	659	40	90	7	5	29.4	32.3
KK13025P1180	25	1180	1298	1011	859	65	90	8	6	34.3	37.2
KK13025P1380	25	1380	1498	1211	1059	90	90	9	7	39.2	42.1
KK13025P1680	25	1680	1798	1511	1359	90	40	11	9	46.5	49.4

Reference edge

Viewed from the motor flange, the reference edge is located on the left side of the linear axis.

KK Linear Axes

KK130

2.6.2 KK130 linear axes with aluminium cover

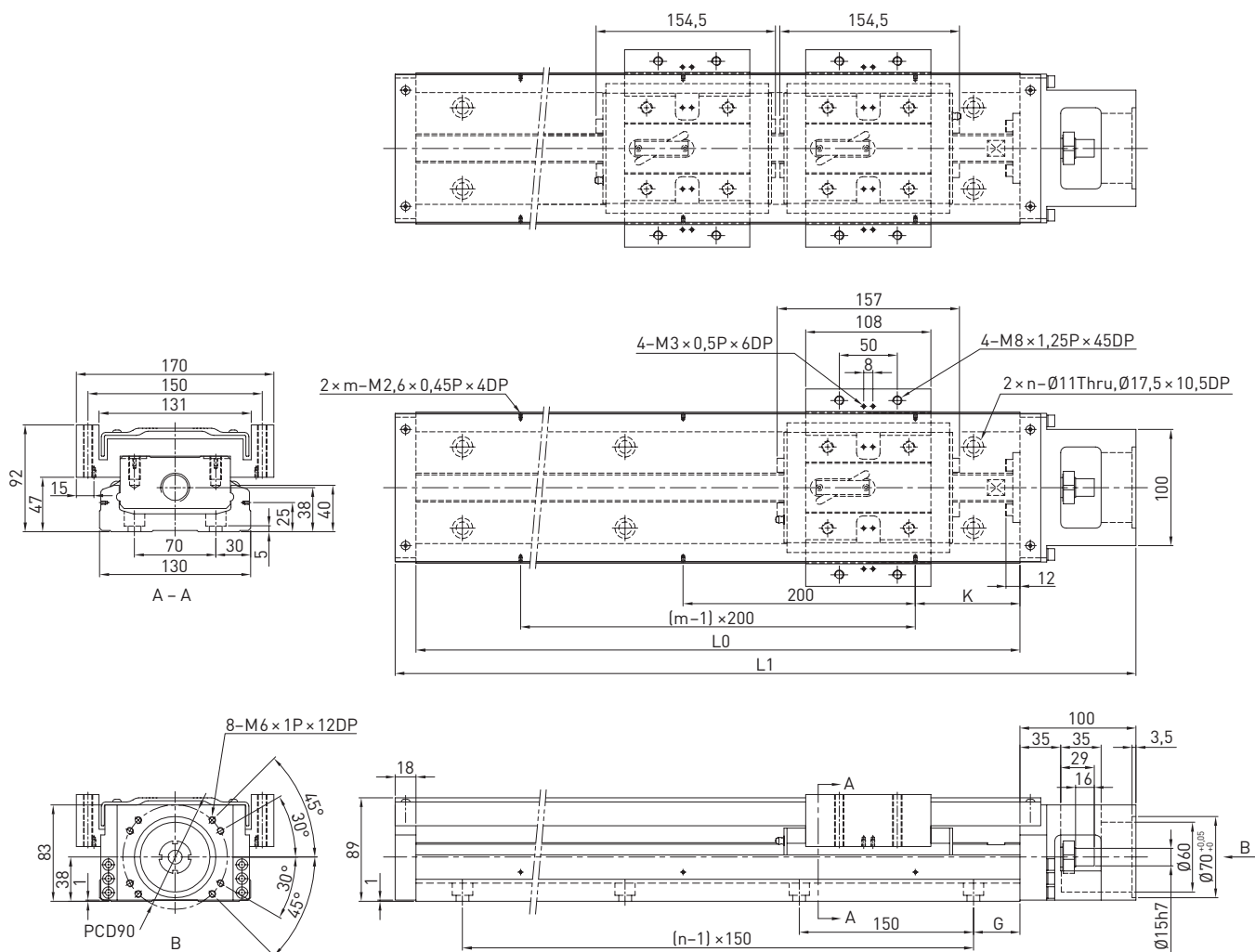

Table 2.18 Dimensions and weights of KK130 linear axes with aluminium cover

Model	lead [mm]	L0 [mm]	L1 [mm]	Maximum stroke [mm]		G [mm]	K [mm]	n	m	Weight [kg]	
				Block A1	Block A2					Block A1	Block A2
KK13025P0980	25	980	1098	811	659	40	90	7	5	31.9	35.9
KK13025P1180	25	1180	1298	1011	859	65	90	8	6	37.1	41.1
KK13025P1380	25	1380	1498	1211	1059	90	90	9	7	42.2	46.2
KK13025P1680	25	1680	1798	1511	1359	90	40	11	9	49.9	53.9

Reference edge

Viewed from the motor flange, the reference edge is located on the left side of the linear axis.

2.6.3 KK130 adapter flanges

Motor adapter flange F0

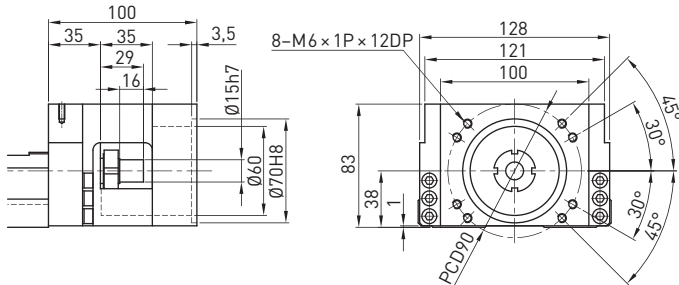

Motor adapter flange F1

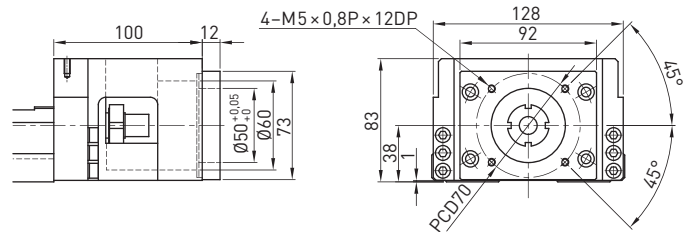

Motor adapter flange F2

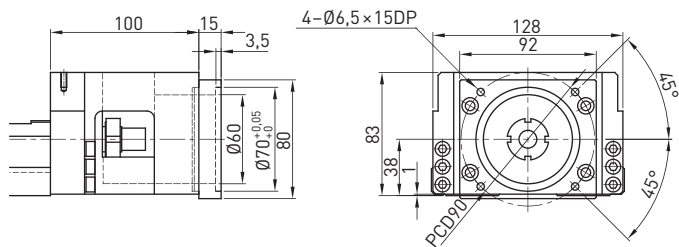

Motor adapter flange F3

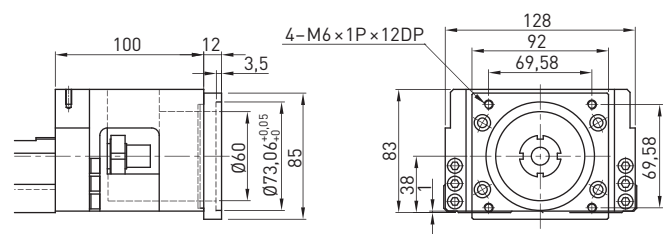

Motor adapter flange F4

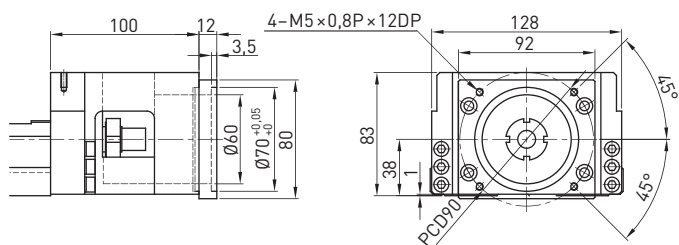

Motor adapter flange F5

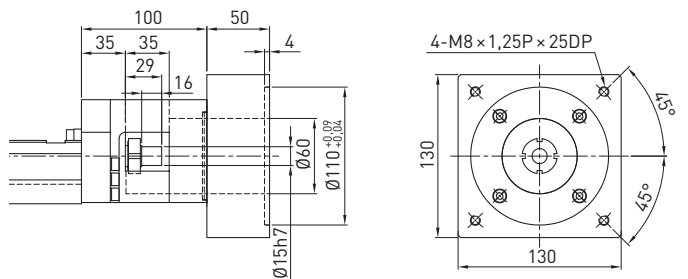

Motor adapter flange H0

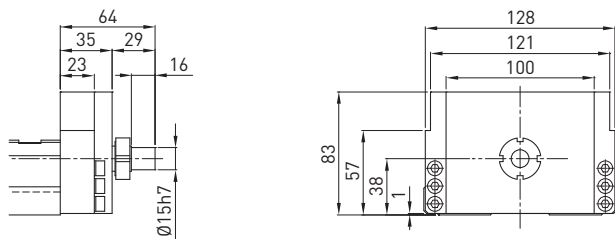

KK Linear Axes

Accessories

3. Accessories for KK linear axes

3.1 HIWIN servo motor

HIWIN synchronous AC servo motors are available with power ratings of 50 W, 100 W, 200 W, 400 W, 750 W and 1000 W. The standard motors are equipped with an incremental encoder (10 000 increments per revolution), and are available with or without a motor brake.

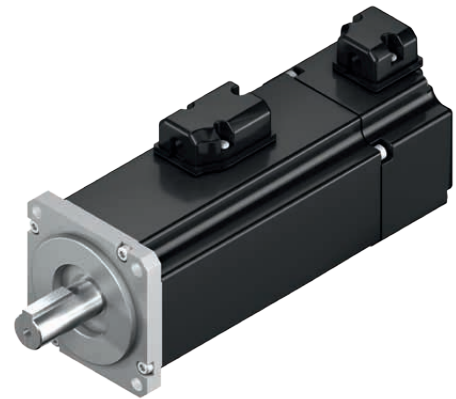

Table 3.1 Motor type to KK linear axis assignment

Motor type	Motor output [W]	Motor torque [Nm]							
		Nominal torque	Peak torque	KK40	KK50	KK60	KK86	KK100	KK130
FRLS05	50	0.16	0.48	●	●	●			
FRLS10	100	0.32	0.96	●	●	●			
FRLS20	200	0.64	1.92				●	●	●
FRLS40	400	1.27	3.81				●	●	●
FRMS75	750	2.40	7.20					●	●
FRMM1K	1000	4.77	14.3						●

The motor and encoder cable connections are provided with a connector for the quick and easy connection of extension cables.

Table 3.2 Motor and encoder cable extension

Length	Motor cable		Encoder cable
	without brake	with brake	
3 m	8-10-0627	8-10-0623	8-10-0751
5 m	8-10-0628	8-10-0624	8-10-0752
7 m	8-10-0629	8-10-0625	8-10-0753
10 m	8-10-0630	8-10-0626	8-10-0754

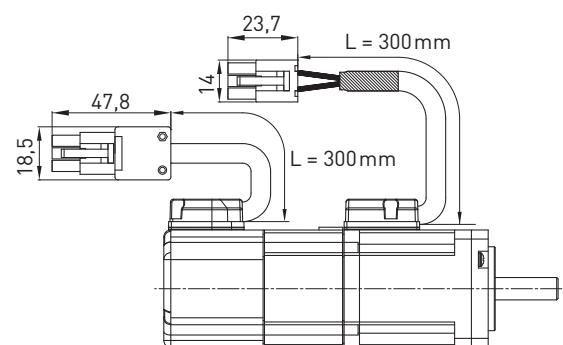

For more information about HIWIN servo motors, please refer to the "Drives & Servo Motors" catalogue or visit www.hiwin.de

3.2 HIWIN D2 servo drive

The compact HIWIN D2 servo drive is specially optimised for HIWIN servo motors and is available in the performance classes 100 W, 400 W and 1000 W. The D2 drive offers the following properties:

- Fully digital, vector-controlled drive
- Autotuning function
- Vibration suppression
- Error compensation
- Integrated PLC function
- Plug-in connections for quick exchange
- 2-line alphanumeric display with 4 control keys on the drive
- Digital pulse-direction interface and analogue +/-10 V interface
- Position control, speed control and torque control
- Inputs/outputs which can be parameterised
- Optional EtherCAT interface with CoE (CAN over EtherCAT) protocol and DS402 drive profile
- Optional mega-ulink interface
- Efficient and freely available "Lightening" commissioning software



Table 3.3 D2 servo drive to motor type assignment

Motor		Servo drive				KK linear axis
Type	Nominal power	Performance class	D2 _{Standard}	D2 _{EtherCAT}	D2 _{mega-ulink}	
FRLS05	50 W	100 W	8-09-0423	8-09-0441	8-09-0445	KK40, KK50, KK60
FRLS10	100 W	100 W	8-09-0423	8-09-0441	8-09-0445	KK40, KK50, KK60
FRLS20	200 W	400 W	8-09-0422	8-09-0442	8-09-0444	KK86, KK100, KK130
FRLS40	400 W	400 W	8-09-0422	8-09-0442	8-09-0444	KK86, KK100, KK130
FRMS75	750 W	1000 W	8-09-0424	8-09-0443	8-09-0446	KK100, KK130

For more information, please consult the assembly and commissioning instructions available at www.hiwin.de. The "Lightening" commissioning software can also be downloaded free from our website.

3.3 Sensor rail with limit switch

The KK linear axis can be ordered with up to three limit switches (inductive PNP proximity switches). The limit switches are mounted on the sensor rail, where they can be placed in any position. The limit switches are supplied with open cable ends and mounted on the sensor rail which is attached to the linear axis. More details of the limit switches can be found in the "KK linear axes assembly instructions" available at www.hiwin.de.

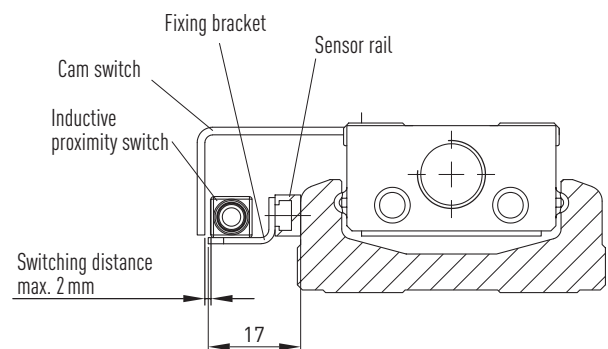

Table 3.4 Available limit switches

Article number	Function	Cable length
8-14-0003 ¹⁾	Normally closed contact	4 m
8-14-0002	Normally closed contact	2 m
8-14-0010	Normally open contact	2 m

¹⁾ Standard version

KK Linear Axes

Accessories

3.4 Cross table adapter

- Adapter for connecting two or more KK axes crosswise into one X-Y system
- Adapter for KK axes available with and without aluminium cover
- Cam switch for limit switch can be adapted
- Black anodised surface
- Delivered in a set including mounting material

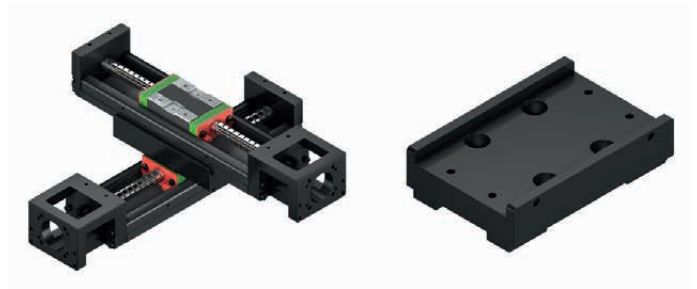

3.4.1 Cross table adapter for KK linear axes without aluminium cover

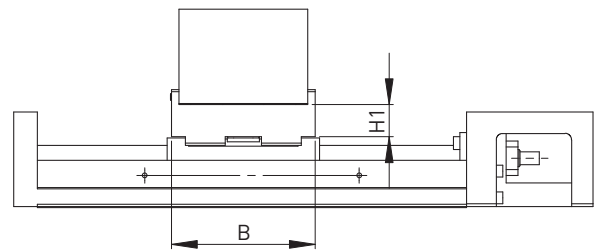
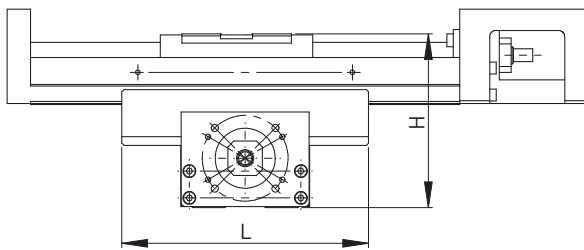

Table 3.5 Dimensions of cross table adapter without cover

Article number	Lower axis	Upper axis	H	H1	L	B
10-000604	KK40	KK40	47	7	70	47
10-000606	KK50	KK40	56	10	70	47
10-000608	KK50	KK50	62	10	90	57
10-000610	KK60	KK50	74	15	90	57
10-000612	KK60	KK60	81	15	115	67
10-000614	KK86	KK60	95	16	110	67
10-000616	KK86	KK86	108	16	120	97

3.4.2 Cross table adapter for KK linear axes with aluminium cover

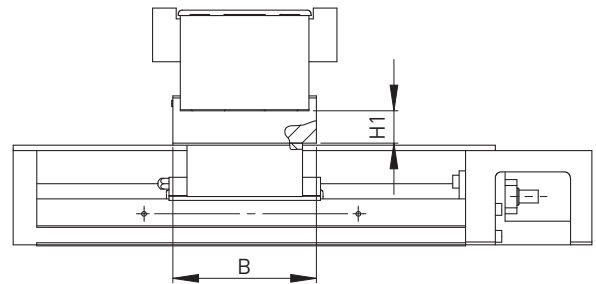
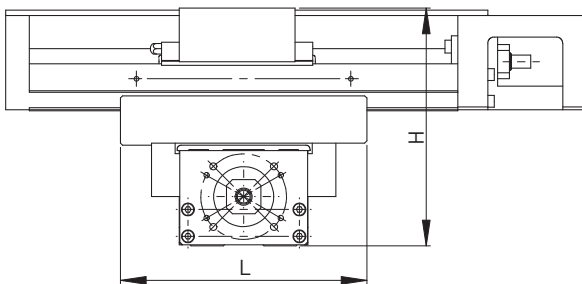

Table 3.6 Dimensions of cross table adapter with cover

Article number	Lower axis	Upper axis	H	H1	L	B
10-000605	KK40	KK40	74	10	70	47
10-000607	KK50	KK40	82	10	70	47
10-000609	KK50	KK50	90	10	90	57
10-000611	KK60	KK50	103	15	57	57
10-000613	KK60	KK60	111	15	115	67
10-000615	KK86	KK60	132	16	144	67
10-000617	KK86	KK86	152	16	144	97

3.5 Covers

To protect the linear axes, they can be fitted with aluminium or bellow covers. You will find the dimensions of the KK linear axes with covers in the chapters for the relevant sizes.

Table 3.7 Availability of covers

Model	Aluminium cover	Bellow cover
KK40	●	
KK50	●	
KK60	●	●
KK86	●	●
KK100	●	
KK130	●	

3.6 Grease nipples

Table 3.8 Nipples for grease lubrication

		
Art. no.: 20-000275 – M3 × 0.5 P KK40	Art. no.: 20-000272 – M4 × 0.7 P KK50, KK60, KK86	Art. no.: 20-000273 – M6 × 0.75 P KK100, KK130



Linear Guideways



Ballscrews

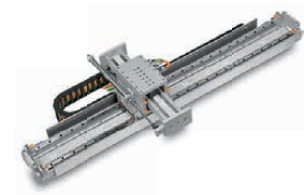

Linear Motor Systems



Linear Axes with Ballscrews



Linear Actuators



Ball Bearings



Linear Motor Components



Rotary Tables



Drives

Germany

HIWIN GmbH
Brücklesbünd 2
D-77654 Offenburg
Phone +49 (0) 7 81 9 32 78 -0
Fax +49 (0) 7 81 9 32 78 -90
info@hiwin.de
www.hiwin.de

Taiwan

Headquarters
HIWIN Technologies Corp.
No. 7, Jingke Road
Nantun District
Taichung Precision Machinery Park
Taichung 40852, Taiwan
Phone +886-4-2359-4510
Fax +886-4-2359-4420
business@hiwin.com.tw
www.hiwin.com.tw

Taiwan

Headquarters
HIWIN Mikrosystem Corp.
No. 6, Jingke Central Road
Nantun District
Taichung Precision Machinery Park
Taichung 40852, Taiwan
Phone +886-4-2355-0110
Fax +886-4-2355-0123
business@hiwinmikro.tw
www.hiwinmikro.tw

Italy

HIWIN Srl
Via Pitagora 4
I-20861 Brugherio (MB)
Phone +39 039 287 61 68
Fax +39 039 287 43 73
info@hiwin.it
www.hiwin.it

Poland

HIWIN GmbH
ul. Puławska 405a
PL-02-801 Warszawa
Phone +48 22 544 07 07
Fax +48 22 544 07 08
info@hiwin.pl
www.hiwin.pl

Czechia

HIWIN s.r.o.
Medkova 888/11
CZ-62700 BRNO
Phone +42 05 48 528 238
Fax +42 05 48 220 223
info@hiwin.cz
www.hiwin.cz

Slovakia

HIWIN s.r.o., o.z.z.o.
Mládežnícka 2101
SK-01701 Považská Bystrica
Phone +421 424 43 47 77
Fax +421 424 26 23 06
info@hiwin.sk
www.hiwin.sk

Switzerland

HIWIN Schweiz GmbH
Eichwiesstrasse 20
CH-8645 Jona
Phone +41 (0) 55 225 00 25
Fax +41 (0) 55 225 00 20
info@hiwin.ch
www.hiwin.ch

France

HIWIN France s.a.r.l.
20 Rue du Vieux Bourg
F-61370 Echauffour
Phone +33 (2) 33 34 11 15
Fax +33 (2) 33 34 73 79
info@hiwin.fr
www.hiwin.fr

Austria

HIWIN GmbH
info@hiwin.at
www.hiwin.at

Hungary

HIWIN GmbH
info@hiwin.hu
www.hiwin.hu

Netherlands
HIWIN GmbH
info@hiwin.nl
www.hiwin.nl

Japan

HIWIN Corp.
mail@hiwin.co.jp
www.hiwin.co.jp

USA

HIWIN Corp.
info@hiwin.com
www.hiwin.com

China

HIWIN Corp.
www.hiwin.cn

Korea

HIWIN Corp.
www.hiwin.kr

Singapore

HIWIN Corp.
www.hiwin.sg